

Introducing the **Polaris** TLS Series of Laser Scanners

New Compact, Powerful, Scanning Technology from Teledyne Optech

The Polaris Terrestrial Laser Scanner (TLS) delivers accurate, precise data faster than ever before, bridging the gap between small, light-weight, short-range sensors and large, long-range, pulsed time-of-flight scanners. Built with surveyors in mind, the Polaris TLS has a user-friendly on-board operator interface with menu-driven operations for quickly collecting and referencing data.

With an integrated high-resolution camera, inclinometers, a compass, a GPS receiver, and weather-proof housing, the Polaris can be deployed in many environments and orientations. The Polaris leads the market in price versus performance, starting at a price that rivals short-range scanners while outperforming most long-range scanners. With accelerated performance and all the built-in features surveyors need, a single Polaris TLS executes more applications than ever before. Whether on a tripod, vehicle, or moving platform, the outstanding performance of the Polaris makes it the most versatile terrestrial laser scanner on the market.



APPLICATIONS

- CIVIL ENGINEERING
- CONSTRUCTION
- TRANSPORTATION
- HERITAGE
- MINING
- FORENSICS
- FORESTRY
- SCIENTIFIC RESEARCH



FEATURES

- LONG-RANGE CAPABILITY
- HIGH-SPEED DATA ACQUISITION
- 100% SCANNER EFFICIENCY
- WIDE, SELECTABLE FIELD OF VIEW
- INTERNAL DATA STORAGE
- INTERNAL CAMERA
- EXTERNAL CAMERA OPTION
- WEATHER-PROOF HOUSING
- AUTOMATIC TARGET RECOGNITION
- USER-FRIENDLY WORKFLOW
- PROJECT PLANNER
- MULTIPLE LIDAR RETURNS
- TILT COMPENSATION
- GPS RECEIVER

The **Polaris** TLS Family...

Versatile Capability for Diverse Data Capture Applications

TLS-250 - Single, fast data collection rate

Ideal for short-range (up to 250 m) applications where documentation and verification are required.

System Performance

TLS-250

Laser repetition rate (peak and effective, kHz)	500
Max range capability @90% reflectivity (m)	250
Max range capability @20% reflectivity (m)	125

TLS-750 - 2 data collection rates for more applications

Two programmable data collection rates and a range capability increased to 750 m plus options such as external cameras and GPS.

System Performance

TLS-750

Laser repetition rate (peak and effective, kHz)	200	500
Max range capability @90% reflectivity (m)	750	250
Max range capability @20% reflectivity (m)	400	125

TLS-1600 - 3 collection rates for longer range capability

The perfect scanner for all applications, with programmable data collection rates that enable ranges over 1600 m.

System Performance

TLS-1600

Laser repetition rate (peak and effective, kHz)	50	200	500
Max range capability @90% reflectivity (m)	1600	750	250
Max range capability @20% reflectivity (m)	775	400	125

Range vs reflectivity

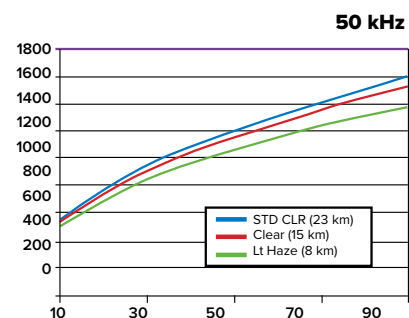
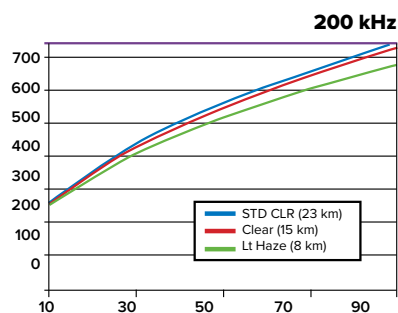
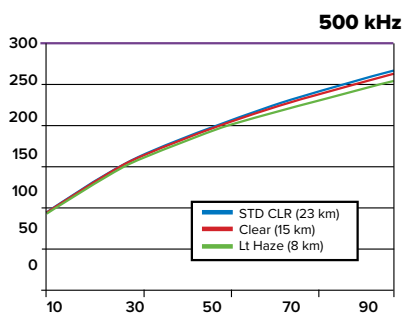



Polaris... Simplified, Touch Screen, Menu-Driven Operation

The Polaris TLS is a stand-alone terrestrial laser scanner that is typically operated via an on-board, sunlight-visible touchscreen. Scans are performed via easy-to-use menu-driven prompts, with data stored locally on the Polaris. After the scan, data is transferred to a Windows-based computer for further processing. Alternatively, you can operate the Polaris via computer, giving you in-depth control and more visibility into scan parameters. The scan data is then stored on the computer for immediate processing, using project-based software features.

GRAPHICAL USER INTERFACE:

- Sunlight-visible
- Resistive single touch
- 640 x 480 pixels
- Color TFT LCD

Polaris ATLAScan Data Processing and Workflow

The Polaris software suite, ATLAScan, is a field-proven, PC-based workflow platform that enables easy operation.

ATLAScan...

- Manages all data associated with a scan project, including point clouds, imagery, GPS, referencing control files, and coordinate conversions, as well as deliverables such as meshes, models, and line work.
- Minimizes processing steps and optimizes functionality to help you shorten your processing times and improve your productivity. ATLAScan also provides tools to view and inspect data, ensuring that your scan coverage is complete and accurate.

ATLAScan's MODULES:

Works	Controls the Polaris scanner, processes and generates geo-referenced point clouds
WorksPro	Provides higher-level deliverables such as feature extraction, meshing, and modeling
Photo	External camera control and integration of imagery onto point clouds
Mobile	Integration with INS system

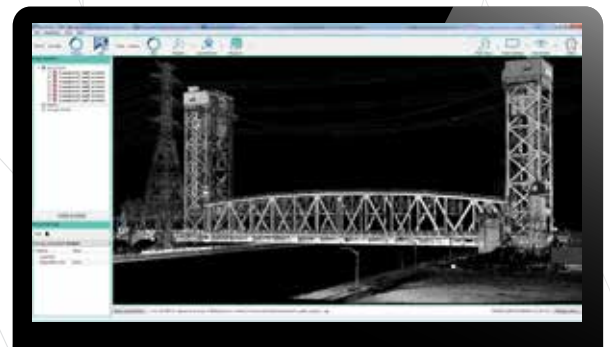

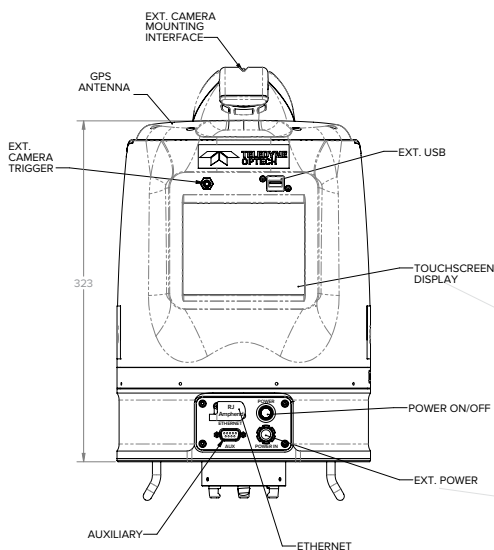
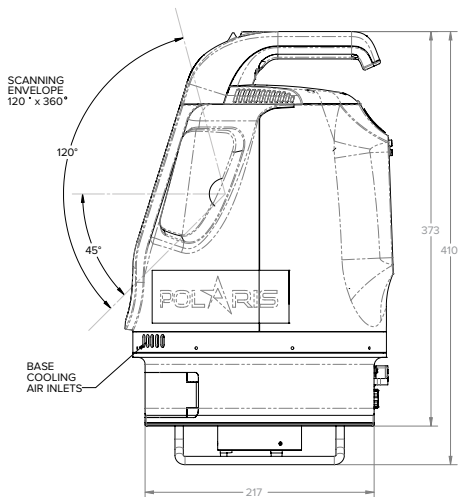
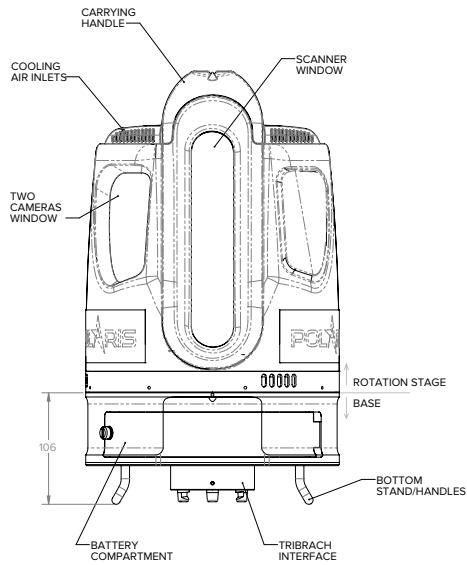

Specifications

Height [mm]	323
Width (diameter) [mm]	250
Total weight [kg]	12

Laser

Range measurement principle	Pulsed
Wavelength [nm]	1550
Laser safety classification	1M
Range resolution [mm]	1
Intensity recording [bits]	12

Scanning Characteristics

Max. vertical field of view [deg]	120
Max. horizontal field of view [deg]	360

Operation Characteristics

Operating temperature: min. [°C]	-10*
Operating temperature: max. [°C]	+50
Humidity range [%]	95
Internal camera	Yes
Control panel built in	Yes

Power

Battery type	Internal or external
Scan time per battery [hr]	2
Power supply input voltage	9-32 VDC

Peripherals

External camera	Yes
Export formats of camera image	JPEG, TIFF, RAW
User interface	Integrated touchscreen, tablet, PC
Additional sensors	Inclination sensor, GPS, compass, plummet
Registration/orientation methods	GPS, backsighting, automated target extraction, resection

Software Functionality

Automatic detection of tie points	Yes
Real-time visualization during scanning	Yes
Geo-referencing	Yes
Fitting of primitives	Yes