



# Trimble Reality Capture

Presented By: Arnaud Lezennec, EMEA Vertical Markets Manager



# Presenter Introduction

Arnaud LEZENNEC - Trimble - EMEA Key Account Manager

- Started 3D Scanning in April 1997 and have been with Trimble for more than 25 years.



# Trimble Laser Scanning

## 3D LASER SCANNING SOLUTIONS

# 01

## Introduction



# 02

## Trimble Scanning HW Portfolio



# 33+ years of developments



1992



2005



2012



2016



2019



2022-23

## Pionnier

SOISIC - 3D Ipsos  
1998 - Cyrax 2400  
2003 - GS100

## Accélération

Startups Acquisitions  
ToF vs. Phase Shift  
Trimble GX  
Trimble Realworks  
2007 - Trimble VX

## Développement

2012 - Trimble TX5  
2013 - Trimble TX8  
Assemblage sans cible

## Diversification

Trimble SX10  
Trimble Business Center  
scanning module  
Trimble Access 3D view

## Expansion

Trimble X7  
Trimble Perspective

## Consolidation

Trimble X12 & X9  
Trimble Perspective

# Trimble Scanning HW Portfolio



## Trimble X12 (250m effective)

Elite model, specialized / highly demanding applications



## Trimble X9 Premium (150m)

Premium, fully featured, total 3D scanning solution



## Trimble X9 Core (80m)

Basic model, dependable, value, standard scanning applications



## Trimble X9 Core LT (40 mètres)

Entry model, ideal to start, fully integrated



# Trimble Scanning Portfolio

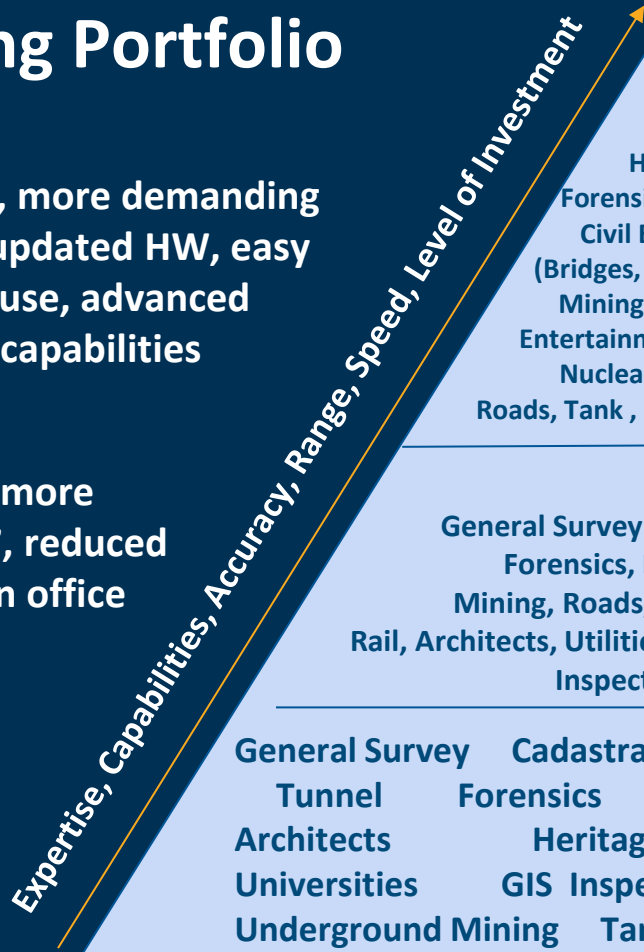

Expert, more demanding jobs, updated HW, easy to use, advanced capabilities

Direct upgrade, more applications than X7, reduced time on-site and in office

New to scanning, everyday jobs w/ confidence

Heritage  
Forensics, Rail, OGC  
Civil Engineering  
(Bridges, Tunnels, Dams)  
Mining, Monitoring,  
Entertainment, City Blocks  
Nuclear, Inspection,  
Roads, Tank , ...

General Survey    Civil Engineering  
Forensics, BIM, MEP, Tunnel  
Mining, Roads, City Blocks, Heritage  
Rail, Architects, Utilities, Tanks, Marine, Warehouse,  
Inspection and more

General Survey    Cadastral    Civil Engineering (small size)  
Tunnel    Forensics    MEP    BIM  
Architects    Heritage    Intersection  
Universities    GIS Inspection    Utilities  
Underground Mining    Tanks    Marine Construction etc...

X12



X9P



X9C



# Trimble X9 Core and LT



High-speed 3D laser scanning system with unique innovations to simplify adoption, increase efficiency and provide confidence in the field.

- Trimble Registration Assist for Simple and fast in-field scan registration
- Laser pointer to measure point and georeference
- Trimble X-Drive for SMART on the fly calibration to help ensure data Quality on every scan
- Professional instrument quality you can trust with IP55 and Industry leading 2 year warranty



# Trimble X9 Premium

Our most versatile solution, offering intermediate range, accuracy and speed with high sensitivity for peak performance anywhere.

- The X9 Premium is the “Big Brother” with speed and range doubled, improvements on angular accuracy, range noise and image processing for seamless augmented productivity and opening of new Horizons
- High sensitivity on difficult surfaces without sacrificing speed, range or accuracy
- Latest innovations on Trimble X-Drive technology for faster auto-calibration to help ensure data Quality on every scan
- Professional instrument quality you can trust with IP55



# Trimble X9 Comparison

## Trimble X9 Lite, Core & Premium

### Trimble X9 Core

Perfect for those looking to break into reality capture, but weary of the risks associated with large up-front investments. The Trimble X9 Core helps you take the first steps in your laser scanning journey without all the hassle. Whether you're looking to expand your offerings to more detailed deliverables, or looking to answer the questions you don't even know you have yet, the X9 Core is the perfect solution to get started with.

#### Perfect for...

- Quick and **easy scanning** workflows
- Augmenting tradition **topographic surveys** with more context
- Urgent inspections such as **accident scene recreation, emergencies**, etc.



REALITY CAPTURE

### X9 Core

Built for those who need to deliver in the moment



REALITY CAPTURE

### X9 Premium

If you want to be right before you need to be right

### Trimble X9 Premium

Being a surveyor means no two days are the same. With so much diversity in your work, you need a solution that can rise to any challenge you throw at it. The Trimble X9 Premium is engineered to do exactly that. Built to measure farther, faster, and finer, the X9 Premium is a scanning powerhouse, helping you capture large areas in a single setup, never missing a detail. Purposely designed to go anywhere you do, the X9 Premium is the perfect kit for any survey that comes your way.

#### Perfect for...

- **Detailed topographic** surveys in a flash
- **Lightning fast** scanning with the density you need to **capture every detail**
- Precise, contextual, **Scan-to-BIM** workflows



# Trimble X12



Accessible high end 3D laser scanning system with superior speed, accuracy, range, and incredible image clarity that was previously not possible (for both confined and large scanning projects)

- Unparalleled ease of use and flexibility with Trimble Perspective and On-Board Interface
- High resolution, accurate point cloud data and ultra fast acquisition
- Sharp, clean image acquisition for breathtaking pointcloud colorization
- Professional instrument quality you can trust with IP54 and Industry leading 2 year warranty



# Trimble SX12



The most **innovative** surveying solution we've ever engineered. The SX12 truly merges high speed 3D scanning, high accuracy surveying measurements and enhanced imaging capability into one seamless solution. This transforms the way surveyors work without requiring them to change the way they work.

- Trimble Lightning 3DM technology for high speed and high precision for all your measurement styles (DR, prism and scanning)
- Best Scanning Range - 600m +
- Best EDM and smallest spot size
- Green Laser Pointer for best visibility (3mm@50m)
- Survey workflow or scanning workflow
- Flexibility to address a wider range of projects



	Scan Speed	Scan Range	Range Noise	3D Point Accuracy	Scan Time	Imaging	Image Acquisition Time	Interface	Dual Axis Compensator	Ingress Protection	Laser Class
<a href="#">Trimble X9 Core</a>	Up to 500 kHz	0.6 m–80 m	< 1.5 mm @ 30 m on 80% albedo	3.0 mm @20 m	2-7 minutes	3 coaxial, calibrated 10MP cameras	1-2 min Standard (2-6min HDR)	WLAN via Trimble Perspective Windows tablet or Perspective Mobile from Apple or Android device	Accuracy <3", Range ±10°	IP55	Laser class 1, eye safe in accordance with IEC EN60825-1
<a href="#">Trimble X9 Premium</a>	Up to 1000 kHz	0.6 m–150 m	< 1.5 mm @ 30 m on 80% albedo	3.0 mm @20 m	1-6 minutes	3 coaxial, calibrated 10MP cameras	1-2 min Standard (2-6 min HDR)	WLAN via Trimble Perspective Windows tablet or Perspective Mobile from Apple or Android device	Accuracy <3", Range ±10°	IP55	Laser class 1, eye safe in accordance with IEC EN60825-1
<a href="#">Trimble X12</a>	Up to 2.187 kHz	0.3 m–250 m; 365 m (Ambiguity Interval)	0.25 mm @ 25 m (136 kHz)	2.2 mm @20 m	1-3 minutes	80 MP panorama, parallax free image matching	2-2.5 min (HDR)	Onboard touchscreen or Trimble Perspective on Windows tablet	Accuracy 14", Range ±0.5°, Resolution 0.001°	IP54	Laser class 1, eye safe in accordance with IEC 60825-1
<a href="#">Trimble SX12</a>	26.6 kHz	0.9 m–600 m	1.5 mm @ 50 m on 18-90% reflectivity	2.5 mm @100 m std dev on sphere target position	12 minutes	3 calibrated cameras in telescope powered by Trimble VISION™ technology	2.5 min Standard	WLAN via Trimble Access	Accuracy 0.5", Range ±5.4', Resolution 0.3"	IP55	Pulsed laser 1550 nm; Laser class 1M



# 03

## Trimble Scanning SW Portfolio



# The Right Solution for the Right Application



## Trimble Perspective

Trimble X7 field and office software.

- ▶ Scanner control
- ▶ Automatic infield registration
- ▶ Dynamic 2D and 3D viewing
- ▶ Labels, annotations, measurements
- ▶ Registration refinement and reports



## Trimble RealWorks

Trimble's flagship scanning software.

- ▶ Scan and image processing
- ▶ Automated registration tools
- ▶ 2D CAD / 3D Models
- ▶ Inspection / Classification
- ▶ 3D animations

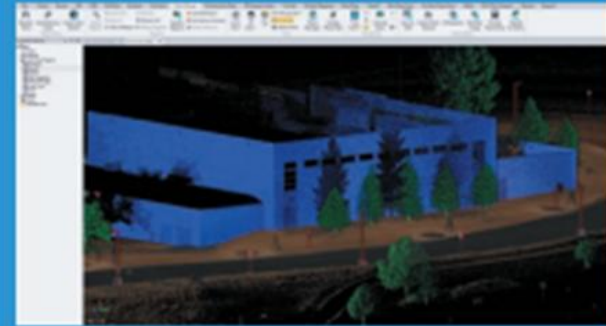

## Trimble Business Center

The industry's leading survey software.

- ▶ Field-to-finish survey software
- ▶ Roadway / corridor sections
- ▶ Volumetrics and earthworks
- ▶ Scan classification / drafting
- ▶ Feature coding

# 03-A

**Why did we create  
Trimble Perspective?**



# 3D Scanning Registration Concept

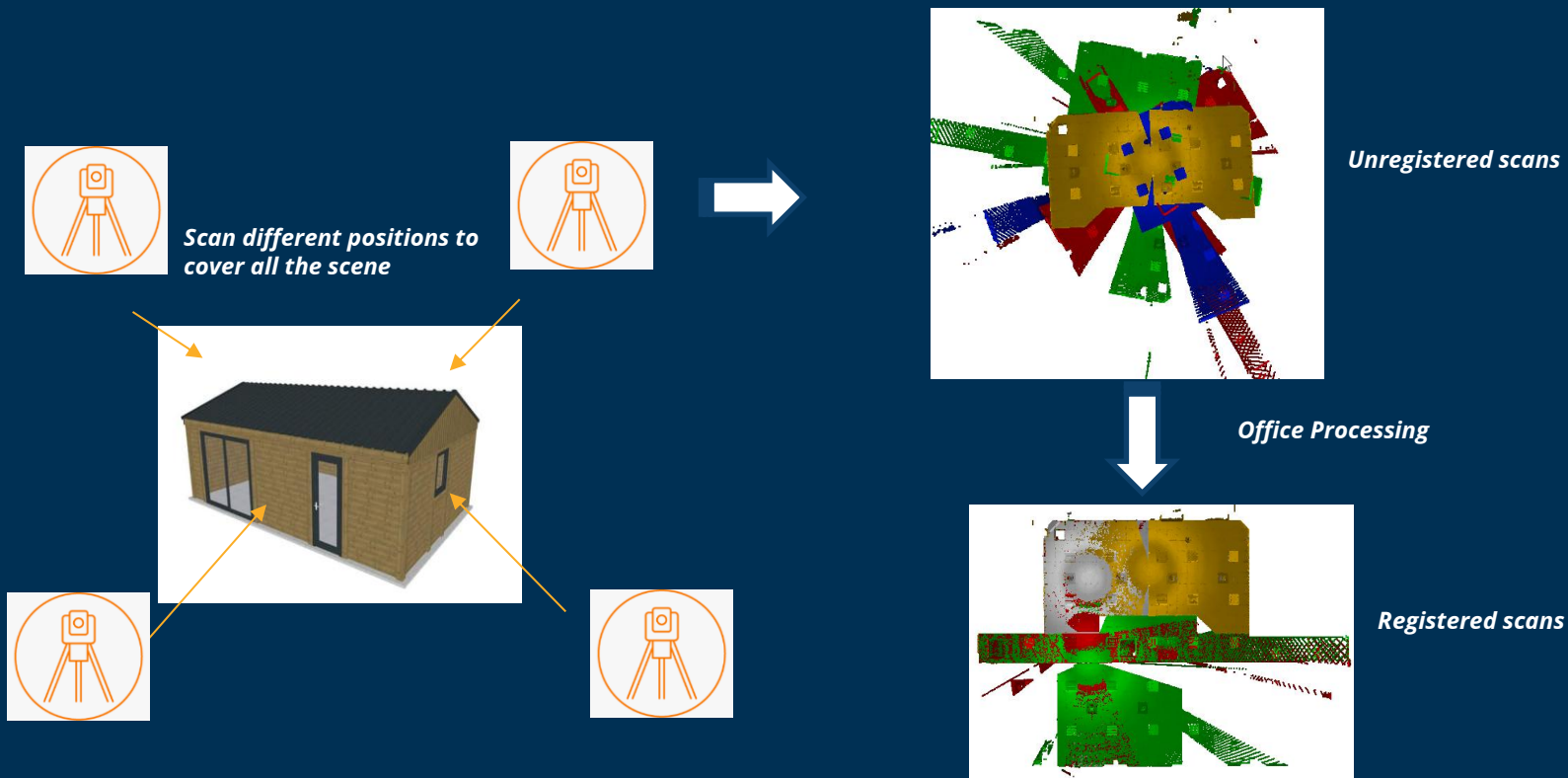

# Standard Scanning Registration Workflow

*Acquire scans and  
hope you collected  
all needed  
information*



*Transfer to  
desktop*



*Import scans in  
Office SW*



*Start  
processing*



*Check/Finalize  
results*



*Process and/or  
Export*

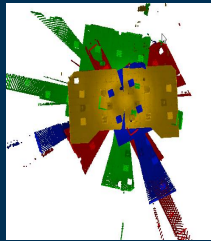
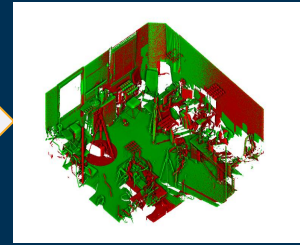

*200 scans ⇒ 1  
night*

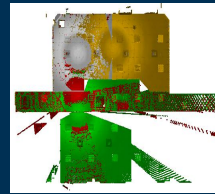

# Trimble Perspective Workflow

*Acquire each scan and register while scanning*

*Check result and finalize in the field*

*Export in The Field*



- *Save time*
- *Never miss a scan, no need to come back*
- *In Field QA/QC*
- *Registration is demystified and becomes a natural step*



# Trimble Perspective Field SW

- Very Intuitive user interface
- 3D data visualization
- Automated Registration
- Annotation, labels and measurement
- Seamless data integration
- Area Scans
- Georeferencing
- Seamless Diagnostic and calibration reports



# Trimble Perspective

## Overview

- Scanner Control
- In-Field Registration
- Georeferencing
- Imagery
- Measurements
- Annotations/Precision Point
- Export

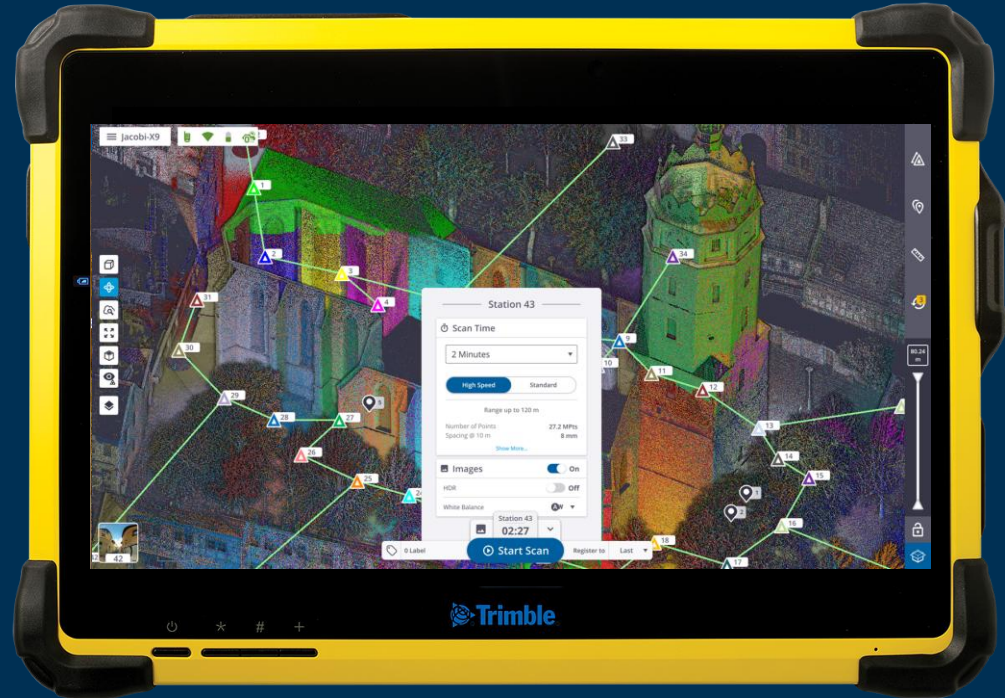

# In-Field Registration

- **Verify** data before leaving worksite
- Utilize **registration assist**
  - Automatic and manual modes
- **Wireless** integration with Trimble tablet
- **Automated IMU** based registration
  - Register in the field to save time in the office
  - Ensure data is complete and correct before you leave the project site
  - Avoid costly rework and additional site revisits



# Automation and Ease of Use

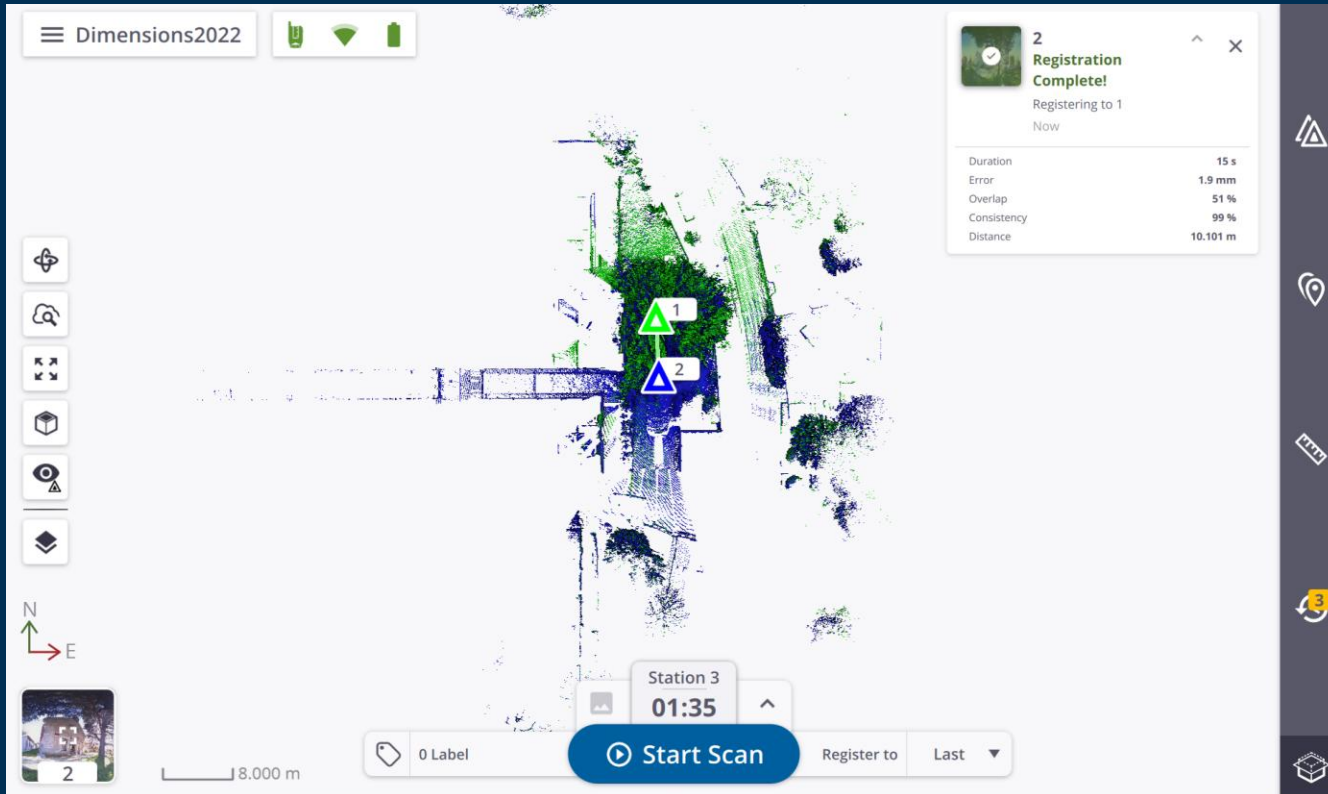

# Quality Assessment

- User guided:

Green: registration is good

Orange: registration has to be visually checked/manually edited

Red: registration failed

- Control values to double check the results
- Direct access to manual registration tool if needed

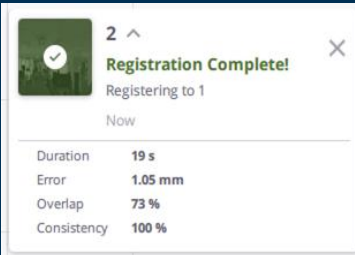

2 ^

**Registration Complete!** ✕

Registering to 1

Now

Duration	19 s
Error	1.05 mm
Overlap	73 %
Consistency	100 %

This notification shows a green checkmark icon, indicating a successful registration. The registration was completed in 19 seconds with an error of 1.05 mm, 73% overlap, and 100% consistency.

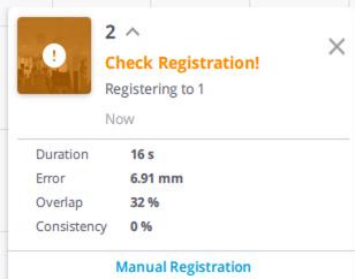

2 ^

**Check Registration!** ✕

Registering to 1

Now

Duration	16 s
Error	6.91 mm
Overlap	32 %
Consistency	0 %

[Manual Registration](#)

This notification shows an orange warning icon with an exclamation mark. The registration parameters are: 16 s duration, 6.91 mm error, 32% overlap, and 0% consistency. A blue link for 'Manual Registration' is provided at the bottom.

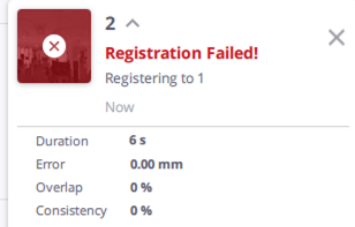

2 ^

**Registration Failed!** ✕

Registering to 1

Now

Duration	6 s
Error	0.00 mm
Overlap	0 %
Consistency	0 %

This notification shows a red error icon with an 'X'. The registration parameters are: 6 s duration, 0.00 mm error, 0% overlap, and 0% consistency.



# Offer an Easy Way to Adjust Registration



# Area Scans

- Scan **specific areas** at a higher density
- Save **time** during your site visit
- Utilize **high resolution** data when and where needed
- **Minimize** the database size and **enhance** data sharing and storage

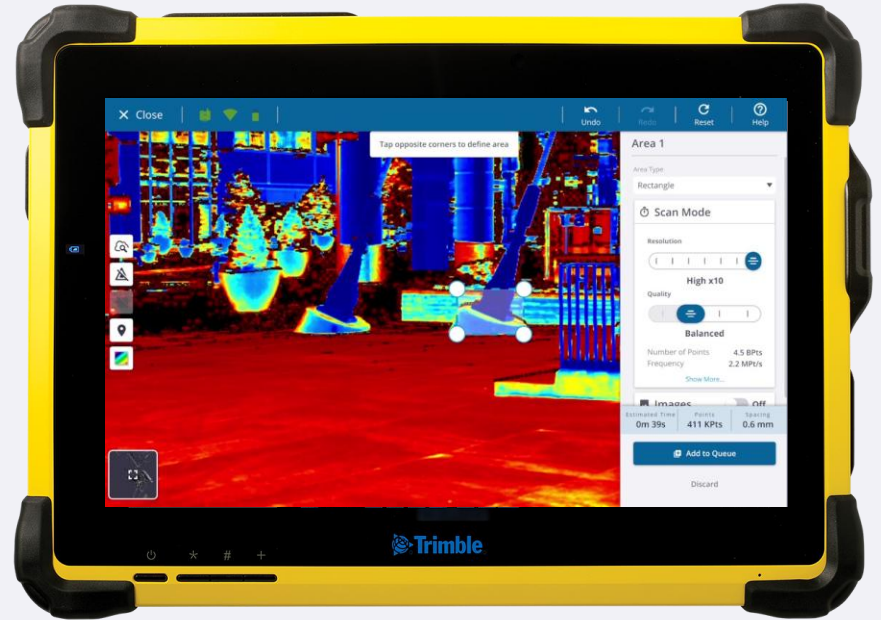

# In-field Measurements

- Measurements at your **fingertips**
  - Horizontal and vertical clearances
  - Areas
  - Distances
  - Single locations
- **Simultaneously** measure and scan
- **Make** decisions and reporting in the field

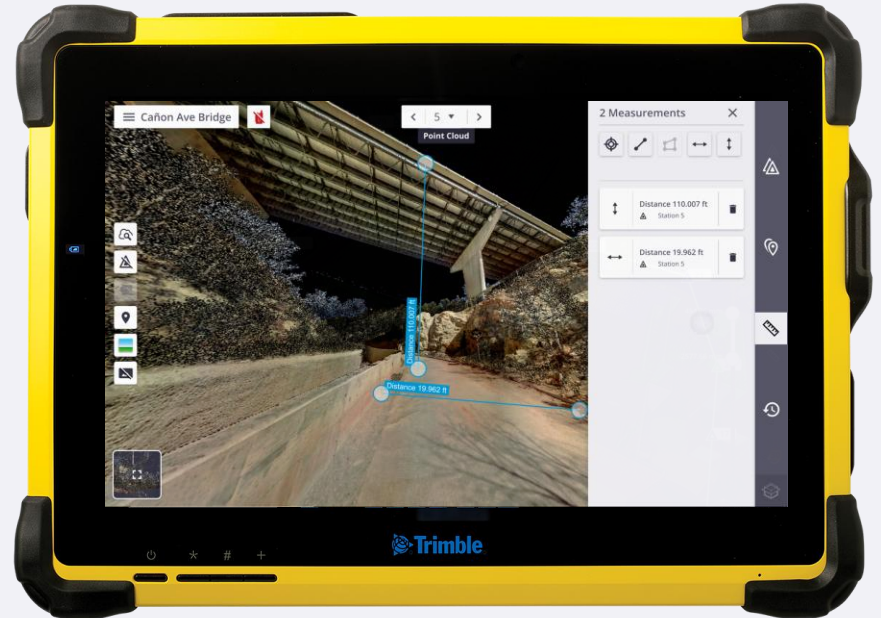

# Labels & Annotations

- Ensure field productivity, while ensuring data quality and accuracy
- Document to control registration and project orientation
- Help office personnel understand the scene
- Available in both 3D and Station-based views
- Key for sharing important information with Stakeholders and clients

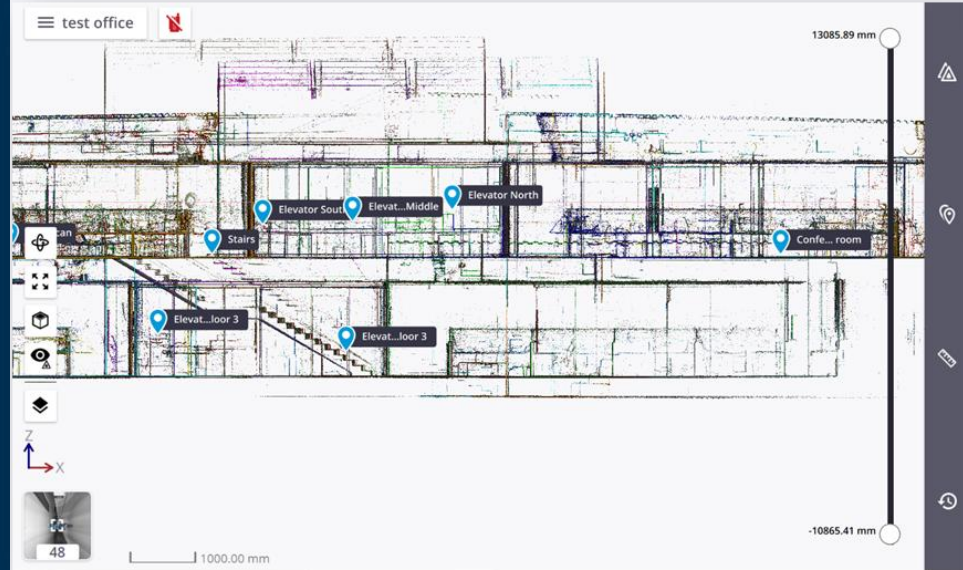

# Retake and Refine

- **Retake** individual images and **refine** scans
  - Original images are retained
- Save time in the office
- Better quality

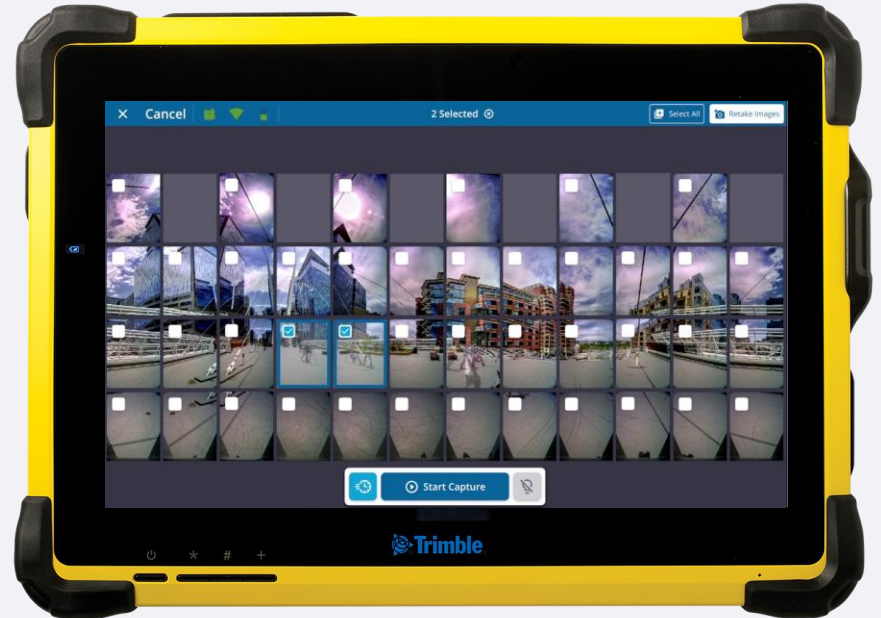

# Georeferencing and export

- Add annotations to label control points in the field
- Key in or import ASCII File to bring in control (CSV, TXT file)
- Productivity and QA/QC

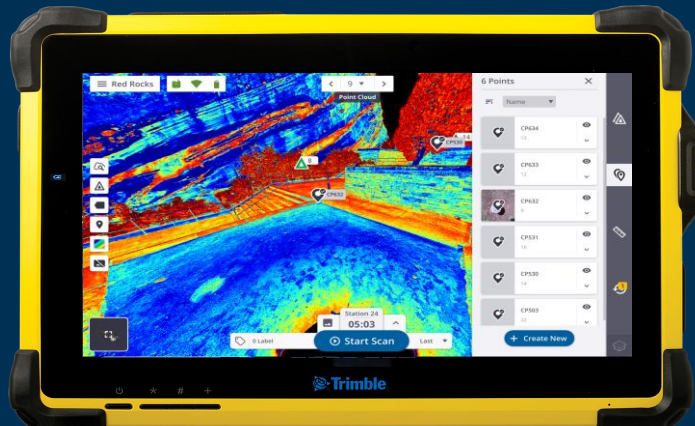

# Georeference Workflow - Registration Report

- Refine Registration
  - Once all Scan Stations have been collected and registered, perform Refine Registration
- Registration Report
  - Display Registration Summary (PDF of HTML File)

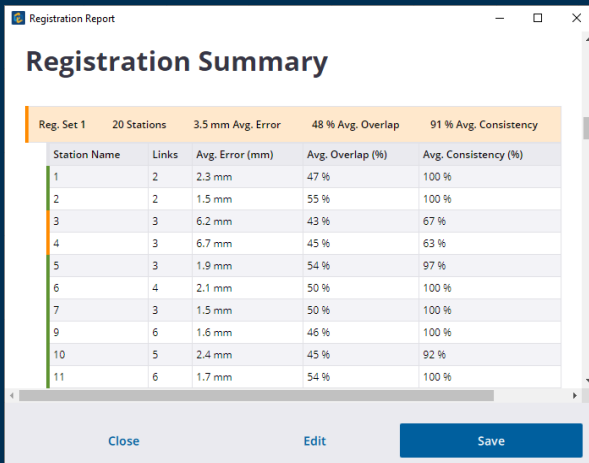

Registration Report

### Registration Summary

Reg. Set 1   20 Stations   3.5 mm Avg. Error   48 % Avg. Overlap   91 % Avg. Consistency

Station Name	Links	Avg. Error (mm)	Avg. Overlap (%)	Avg. Consistency (%)
1	2	2.3 mm	47 %	100 %
2	2	1.5 mm	55 %	100 %
3	3	6.2 mm	43 %	67 %
4	3	6.7 mm	45 %	63 %
5	3	1.9 mm	54 %	97 %
6	4	2.1 mm	50 %	100 %
7	3	1.5 mm	50 %	100 %
9	6	1.6 mm	46 %	100 %
10	5	2.4 mm	45 %	92 %
11	6	1.7 mm	54 %	100 %

Close   Edit   Save

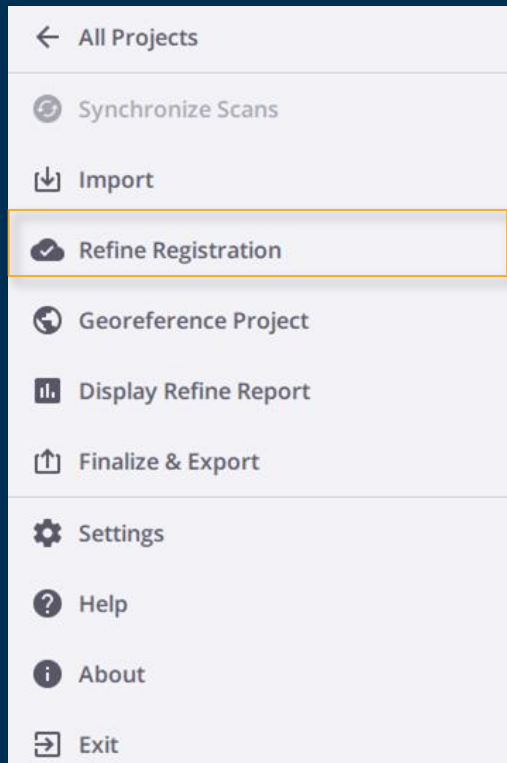

# Quality Control & Reporting

- Diagnostic Report
  - Show the testing results on all components in the Trimble X7 instrument
- Field Calibration Report
  - Show the calibration results when required

The screenshot shows the 'Settings' menu with 'Scanner' selected. The main area displays 'Scanner' information for 'TRIMBLE-X7-02011' (R2.1.7). It features four status indicators: Wi-Fi (91%), Battery (54%), Storage (16GB/29GB, 62 scans left), and Report. Below these are buttons for 'Advanced', 'Erase all scans', 'Check Disk', 'Format SD Card', 'Diagnostic', 'Field Calibration', 'Last Diagnostic', and 'Last Calibration'.

The screenshot shows the 'Calibration Details' report for a Trimble instrument. The report is organized into sections for different accuracy types, each with a 'PASS' status indicator.

**Condition** | ● PASS

Runtime	13 min
Temperature	21 °C
Inclination	1.3 °
Vibration	Low
Ambient light	● PASS

**Angular Accuracy** | 21" | ● PASS

Horizontal Accuracy	● PASS
Vertical Accuracy	● PASS
Trunnion Axis Error	● PASS

**Tilt Accuracy** | <3" | ● PASS

Tilt Accuracy	● PASS
---------------	--------

**Laser Pointer Accuracy** | +/- 5" | ● PASS

Horizontal Collimation Error	● PASS
Vertical Collimation Error	● PASS
Trunnion Axis Error	● PASS

**Distance Accuracy - Standard** | ● PASS

Distance Offset	● PASS
Albedo Corrections	● PASS
Distance Corrections	● PASS

**Distance Accuracy - High Sensitivity** | ● PASS

Distance Offset	● PASS
Albedo Corrections	● PASS
Distance Corrections	● PASS

The Trimble i7 automatically checks the calibration prior to each scan and re-calibrates if needed to ensure the instrument is operating within specifications in current environmental conditions. See the disclaimer for instrument specifications. For the most recent calibration file, the user will be notified and the scan will not start. The Field Calibration Report enables users to produce a report to show the calibration results when required. Contact your dealer if you have persistent failures.

06.10.2020 | 09:21



General

Units

Images

**Scanner**

System Logs



# Diagnostic Report



**Diagnostics Success**

Everything is in order!

## Scanner Information

Firmware

R2.1.3

Close

Generate Support File

Save

Instrument LED Color

General

Units

Images

Scanner

System Logs



# Diagnostics Details

## Wi-Fi ✓ PASS

Wi-Fi Channel	Manual
Wi-Fi Current Channel	48
Wi-Fi Country Code	US

## Mainboard ✓ PASS

Firmware	R2.1.2	<span>✓ Pass</span>
----------	--------	---------------------

## Profiler ✓ PASS

Firmware	R2.1.2	<span>✓ Pass</span>
----------	--------	---------------------

## Camera ✓ PASS

Firmware	R2.1.2	<span>✓ Pass</span>
----------	--------	---------------------

## Deflection Unit ✓ PASS

Firmware	T0.3.32	<span>✓ Pass</span>
----------	---------	---------------------

## Tilt Sensor ✓ PASS

Close

Generate Support File

Save

Instrument LED Color

General

Units

Images

**Scanner**

System Logs



# Field Calibration Report



**Field Calibration Success**

Everything is in order!

## Scanner Information

Firmware

R2.1.3

Close

Generate Support File

Save

Instrument LED Color

General

Units

Images

Scanner

System Logs



# Calibration Details

Condition ✓ PASS

Runtime	7 min
Temperature	42 °C
Inclination	0.2 °
Vibration	Low
Ambient light	<span>✓ Pass</span>

Angular Accuracy 21" ✓ PASS

Horizontal Accuracy	<span>✓ Pass</span>
Vertical Accuracy	<span>✓ Pass</span>
Trunnion Axis Error	<span>✓ Pass</span>

Tilt Accuracy <3" ✓ PASS

Tilt Accuracy	<span>✓ Pass</span>
---------------	---------------------

Laser Pointer Accuracy +/- 5" ✓ PASS

Close

Generate Support File

Save

Instrument LED Color

General

Units

Images

Scanner

System Logs

### Field Calibration Report

Tilt Accuracy | <3" | ✓ PASS

Tilt Accuracy	<span>✓ Pass</span>
---------------	---------------------

Laser Pointer Accuracy | +/- 5" | ✓ PASS

Horizontal Collimation Error	<span>✓ Pass</span>
Vertical Collimation Error	<span>✓ Pass</span>
Trunnion Axis Error	<span>✓ Pass</span>

Distance Accuracy - Standard | ✓ PASS

Distance Offset	<span>✓ Pass</span>
Albedo Corrections	<span>✓ Pass</span>
Distance Corrections	<span>✓ Pass</span>

Distance Accuracy - High Sensitivity | ✓ PASS

Distance Offset	<span>✓ Pass</span>
Albedo Corrections	<span>✓ Pass</span>
Distance Corrections	<span>✓ Pass</span>

The Trimble X7 automatically checks the calibration prior to each scan and re-calibrates if needed to ensure the instrument is operating within specification in current environmental conditions. See the datasheet for instrument specifications. If for any reason the calibration fails, the user will be notified and the scan will not start. The Field Calibration Report enables users to produce a report to show the calibration results when required. Contact your dealer if you have persistent failures.

7/20/2020 | 7:02 PM

Close

Generate Support File

Save

Instrument LED Color

# UI/UX Design

- iF Design Award 2021
- Red Dot Design Award 2021
- New York Design Award 2020



# Trimble Perspective Mobile

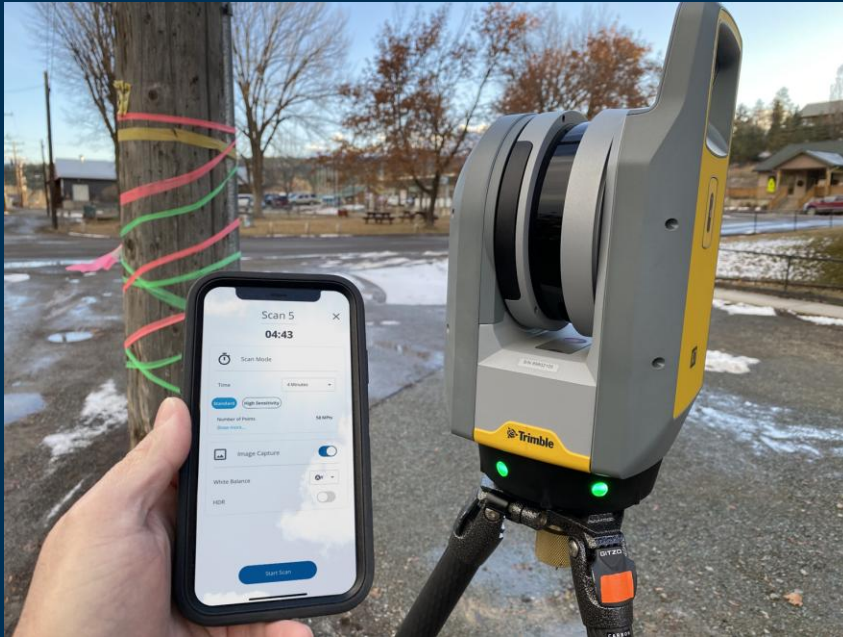

Download now for Android in the Google Play Store or for iOS in the Apple App store to control your scanner from your phone



# Desktop

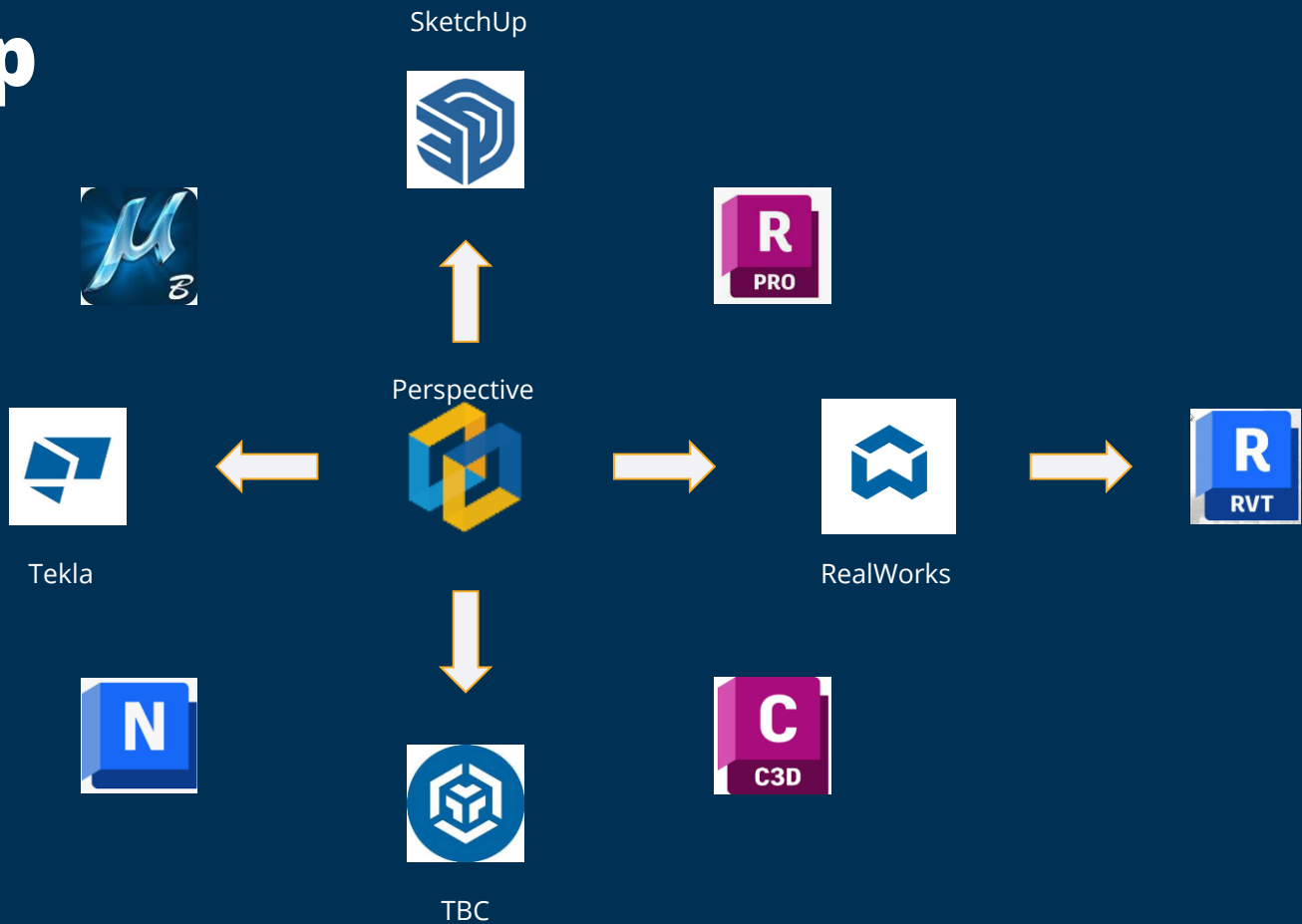

# Field Link Product Palette

X9 Scanner



GNSS / SPS 986



Robotic Total Stations



Field Tablets



Trimble Field Link software

Data Preparation

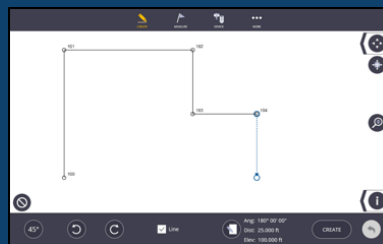

Field Link Office

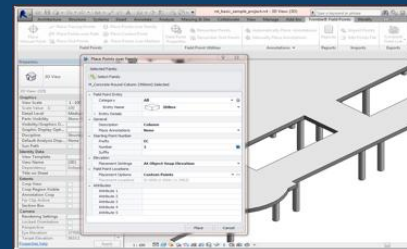

Field Points - Autodesk plugin



# Field Link Scan module

- **FieldLink:** One software, multiple field hardware applications
- View Scan data, model and setting out data in same file
- Create section views and export
- Panoramic images
- Take measurements and annotations
- Surface / floor flatness analysis
- Refined registration and colourisation
- Export direct to CAD platforms
  - TDX / RWP / TZF / RCP / e57 / LAS



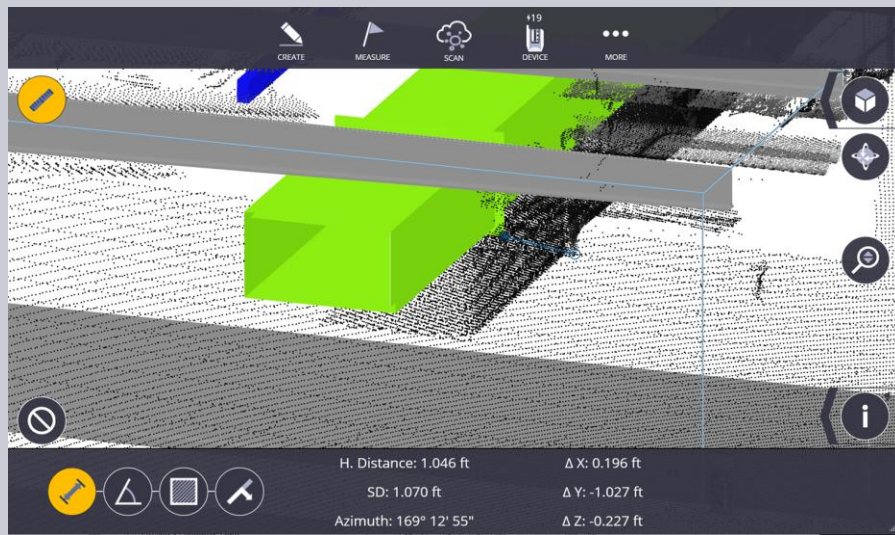

# Compare Model & Point Cloud

View scan data, images, model, and layout points in the same project

Display BIM data

Visually compare

Measure between model & scan

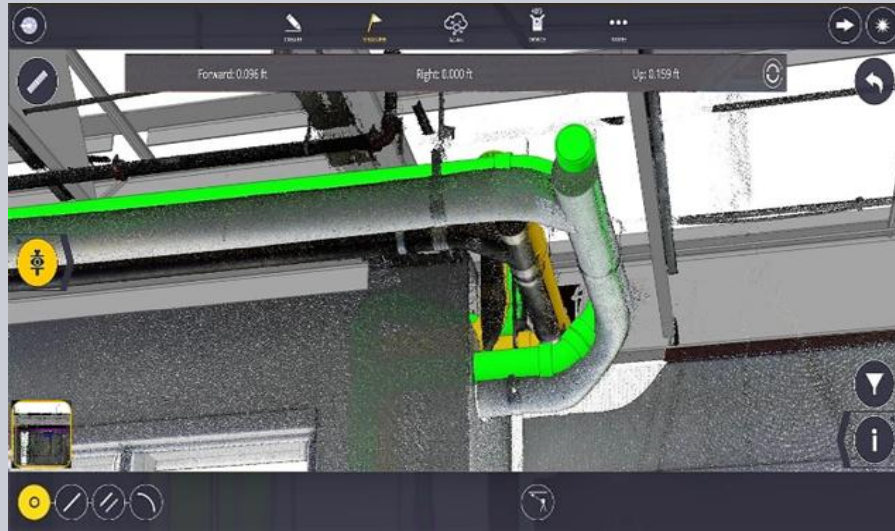

# Scan to BIM for Facilities

Embed Infield QA/QC

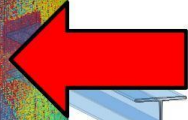

FieldLink  
Connected Construction

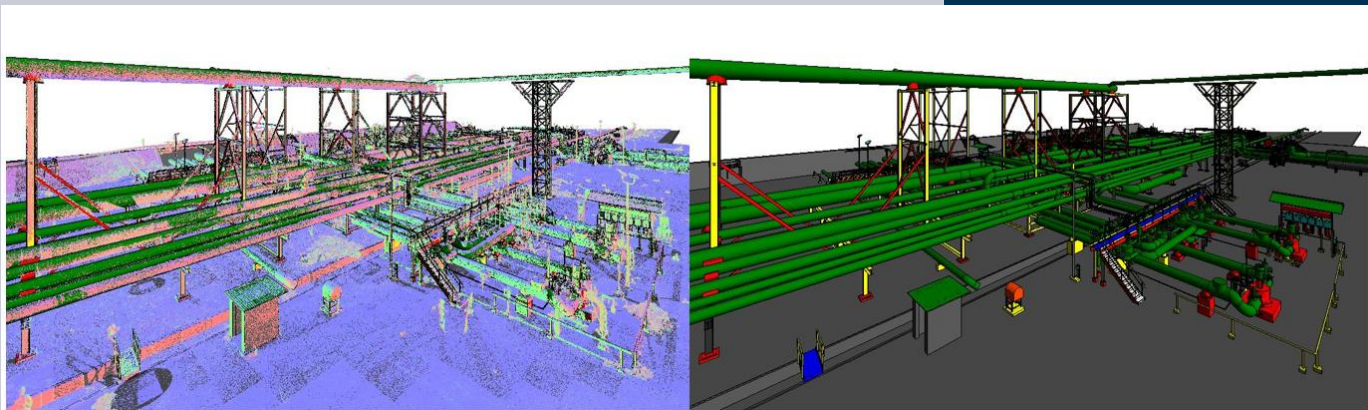
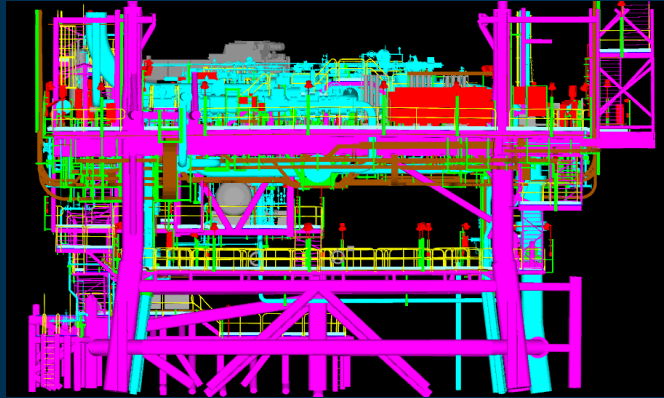

## Floor Report

Date	Wednesday, October 21, 2020
Time	12:57:47 PM
FieldLink Job	shaw
<b>Total Points</b>	6660
<b>High Points</b>	113 (2%)
<b>In Tolerance Points</b>	5540 (83%)
<b>Low Points</b>	536 (8%)
<b>Elevation</b>	0 ft
<b>Tolerance</b>	1/8"
<b>Highest Elevation</b>	3 7/16"
<b>Median Elevation</b>	-1/16"
<b>Lowest Elevation</b>	-5/16"
<b>High Contours</b>	31
<b>Total High Area</b>	34.753 ft <sup>2</sup>
<b>Total High Volume</b>	0.004 yds <sup>3</sup>
<b>In Tolerance Contours</b>	15
<b>Total In Tolerance Area</b>	5414.833 ft <sup>2</sup>
<b>Low Contours</b>	124
<b>Total Low Area</b>	267.219 ft <sup>2</sup>
<b>Total Low Volume</b>	0.034 yds <sup>3</sup>

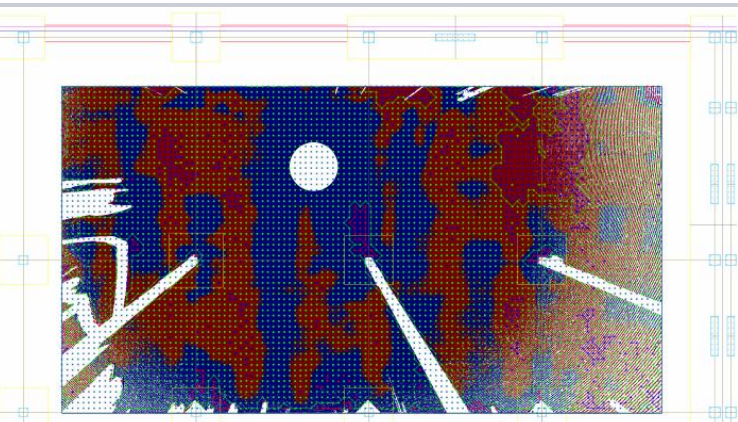

# Floor Analysis

## Floor Report

- Number of high & low points
- Points within tolerance
- High/Low contours
- Volume calculations
  - Volume high area
  - Volume low area

# Verify with Basic Point Layout

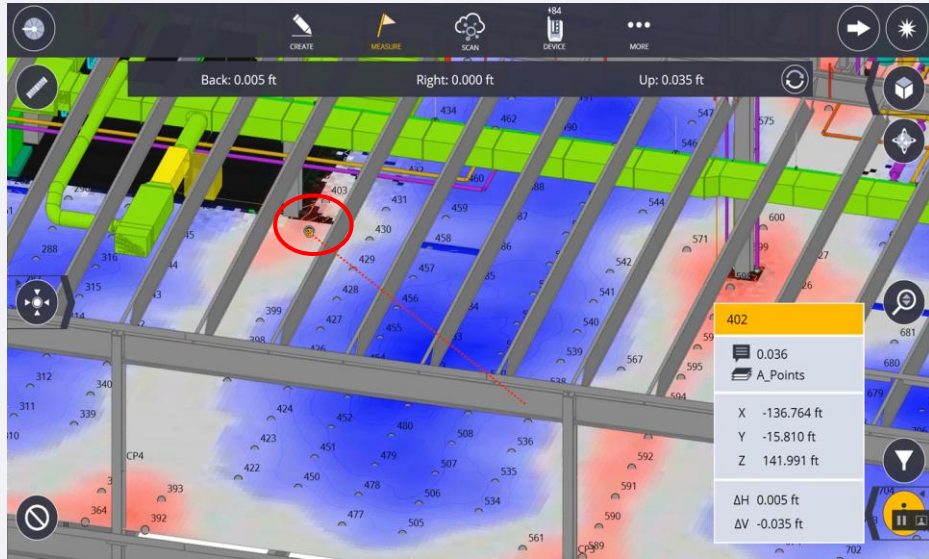

# Trimble RealWorks Office Solution

- Supports virtually any scanner/point cloud
- Automatic registration of Scanning or Survey workflows
- Simple workflow for point cloud based deliverables
- Orthophoto
  - Floor flatness analysis
  - 3D inspection, etc.
  - Classification

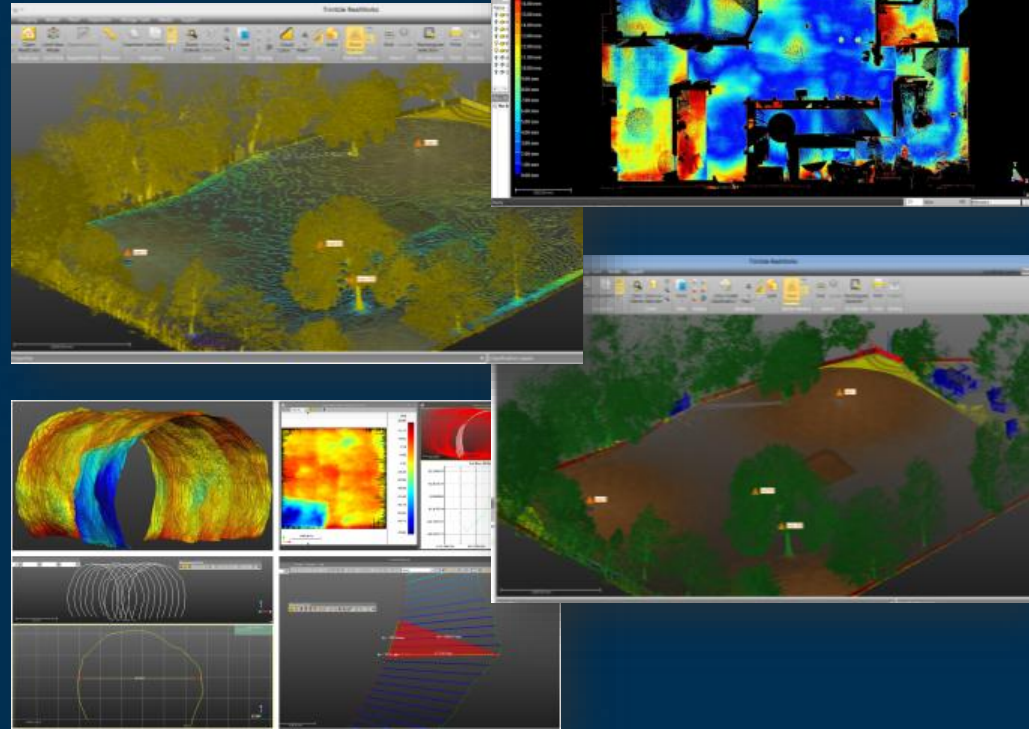

# Trimble RealWorks Office Solution

- Modeling (cloud fitting)
- Storage Tanks
- AutoCAD, Revit, SketchUp integration
- Project sharing (Publisher)

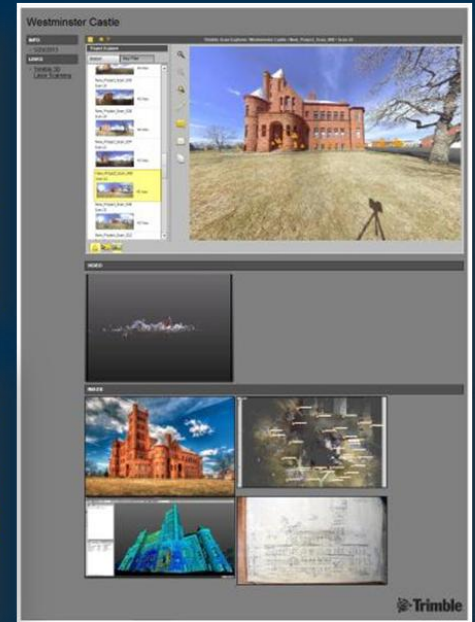
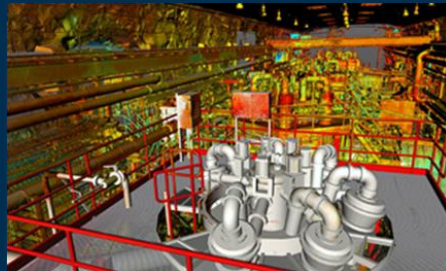
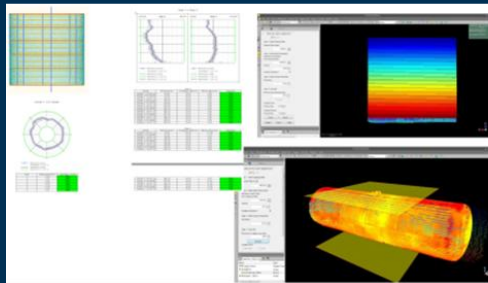

# Registration

Automated target and targetless

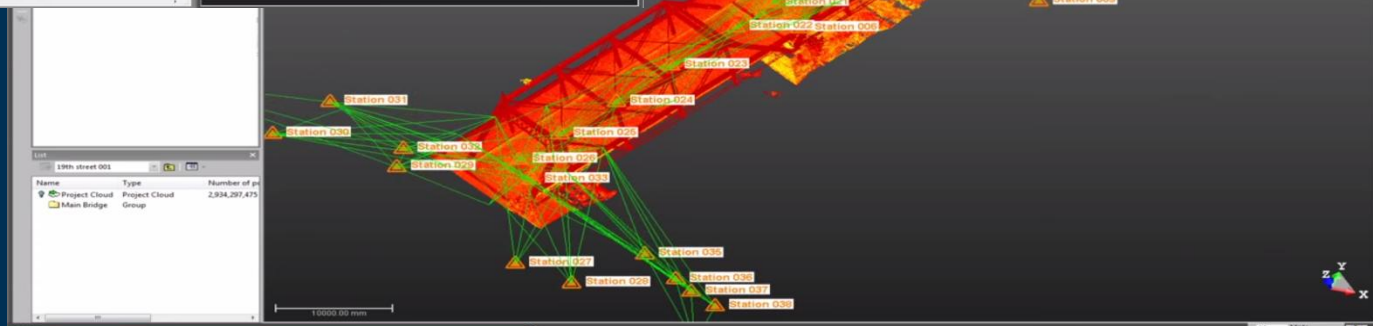
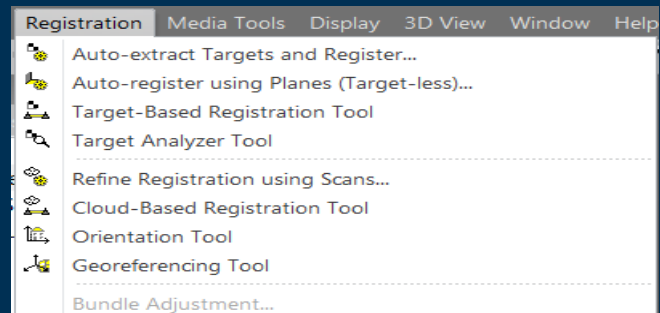
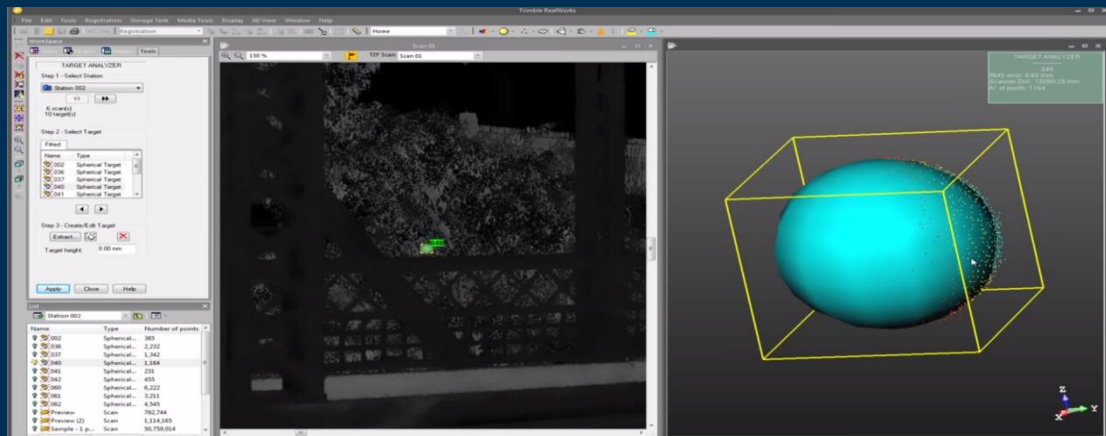

# Outdoor and Indoor Classification + Tanks

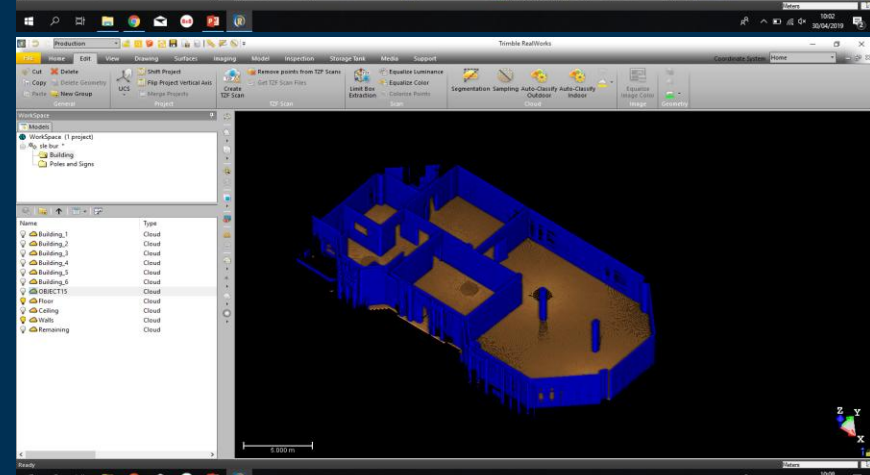
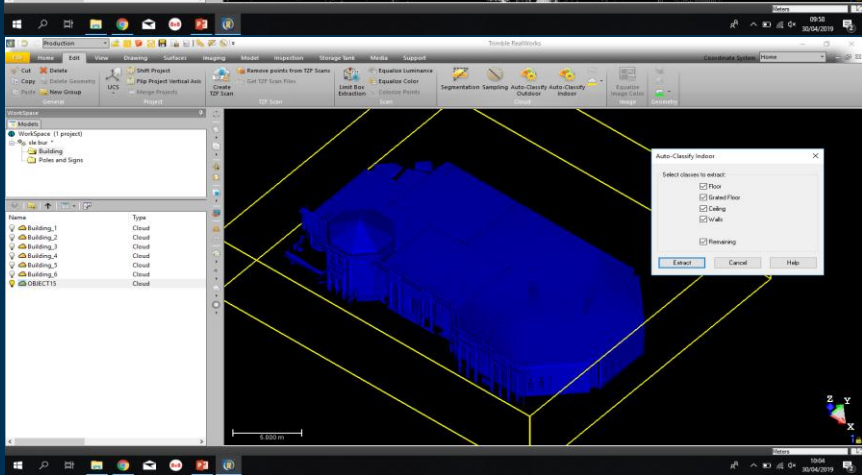
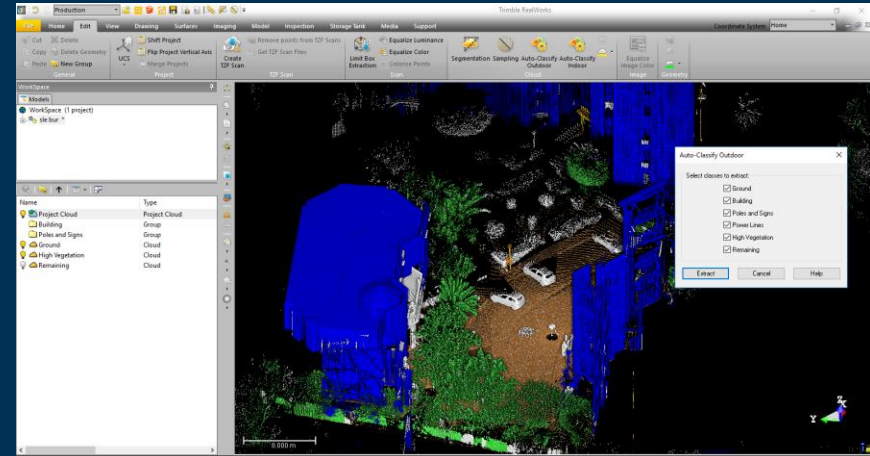
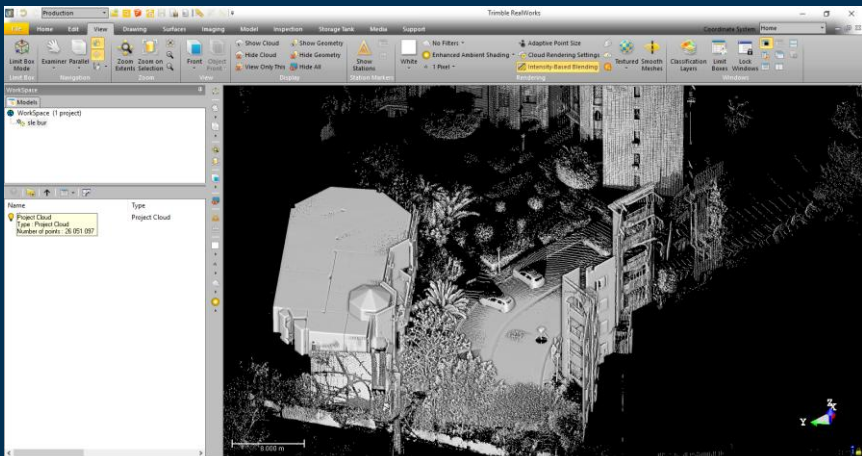

# High density and Large Datasets



# Inspections: 2.5D & 3D

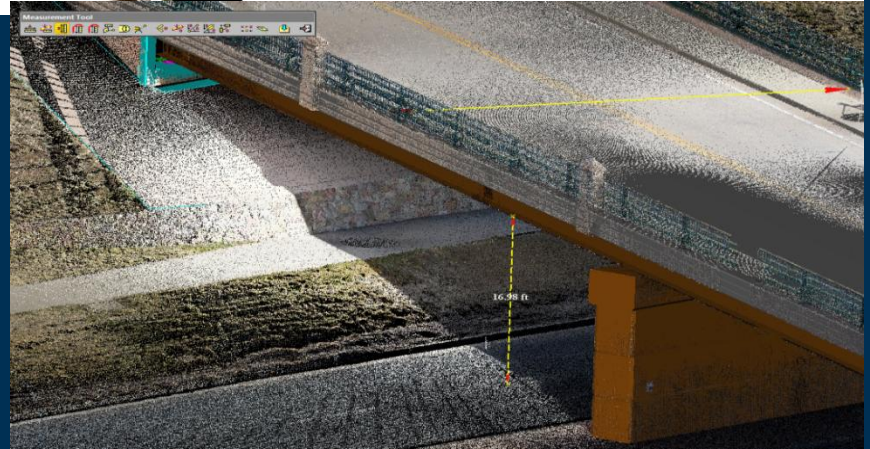
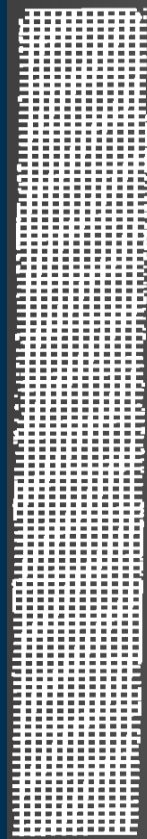
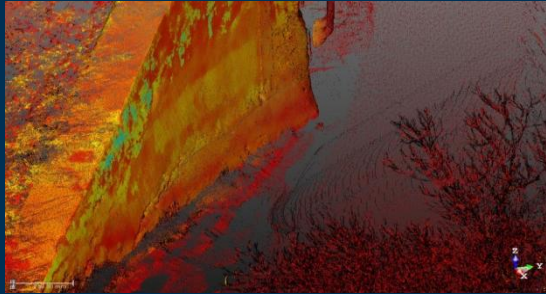
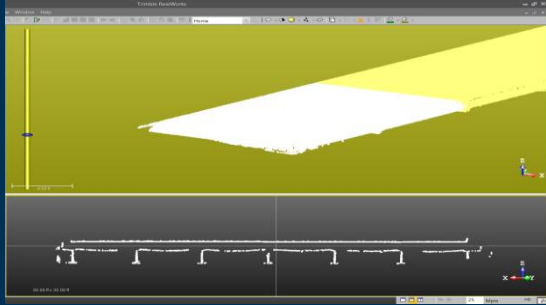

# Orientation and Measurement \*

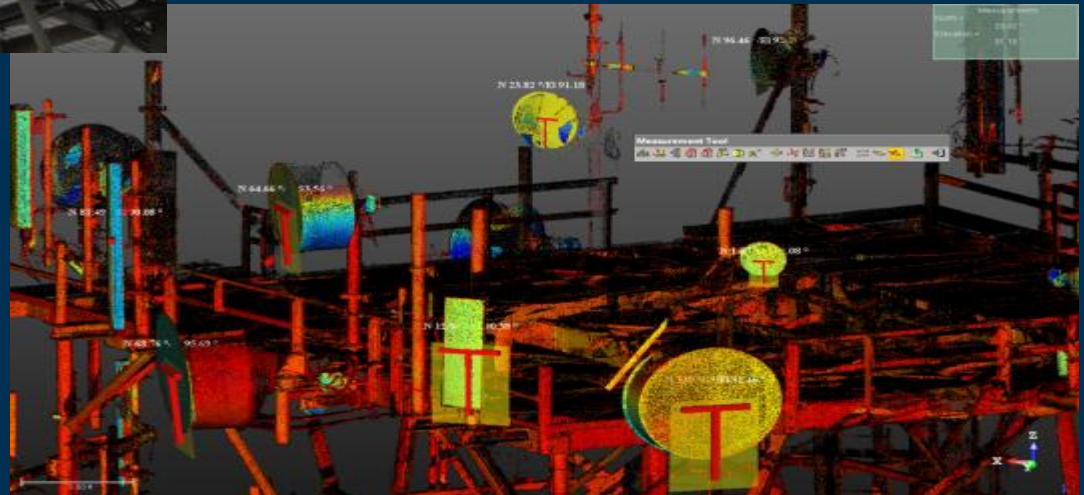
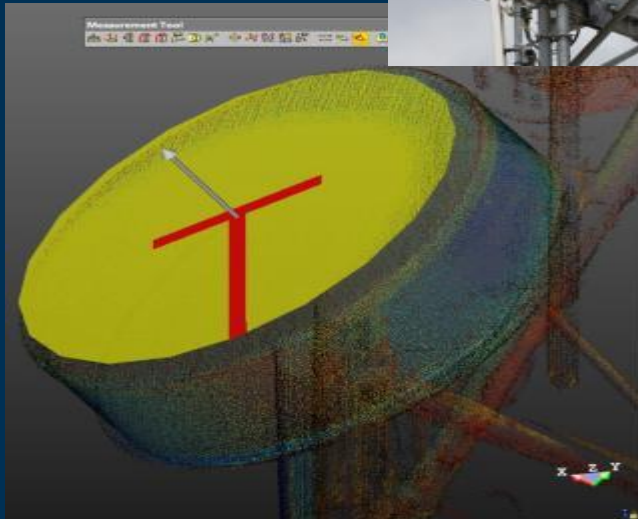

# Modeling and Clearances\*

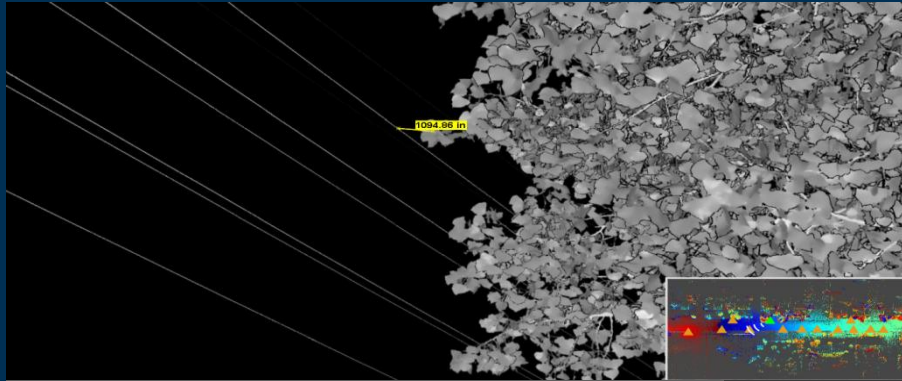

Catenary

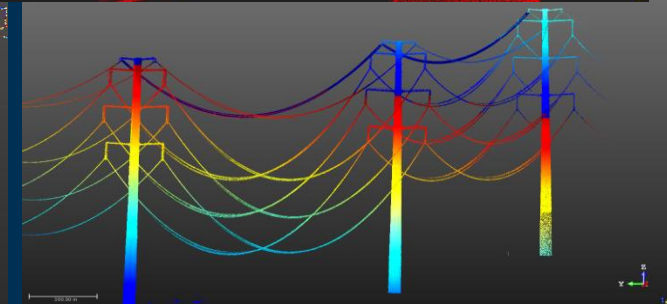
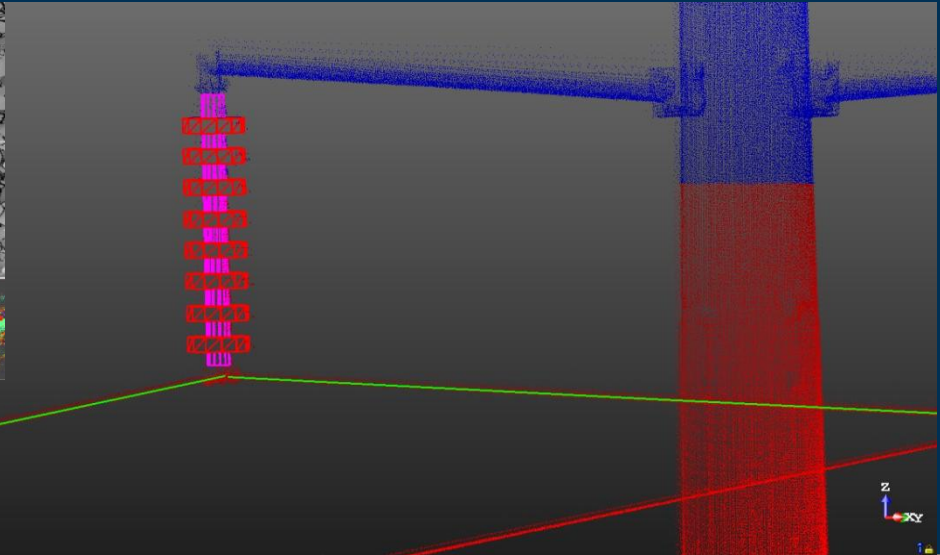
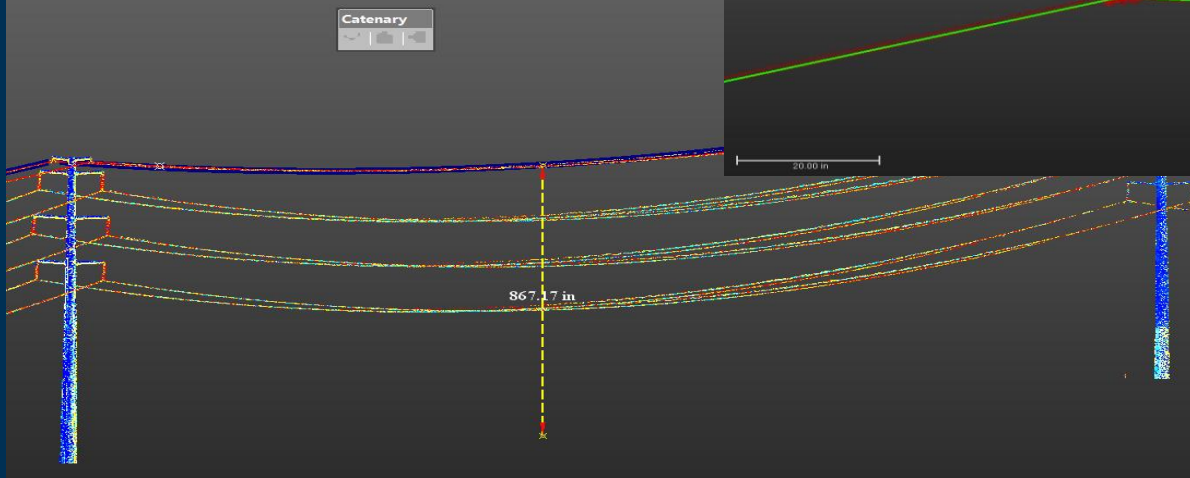

# Planning and Safety

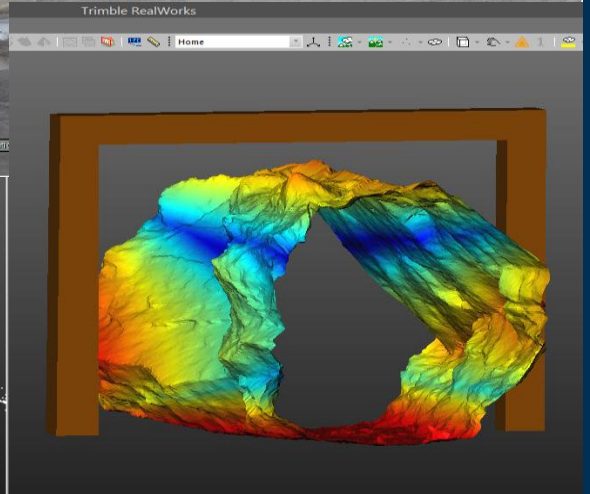
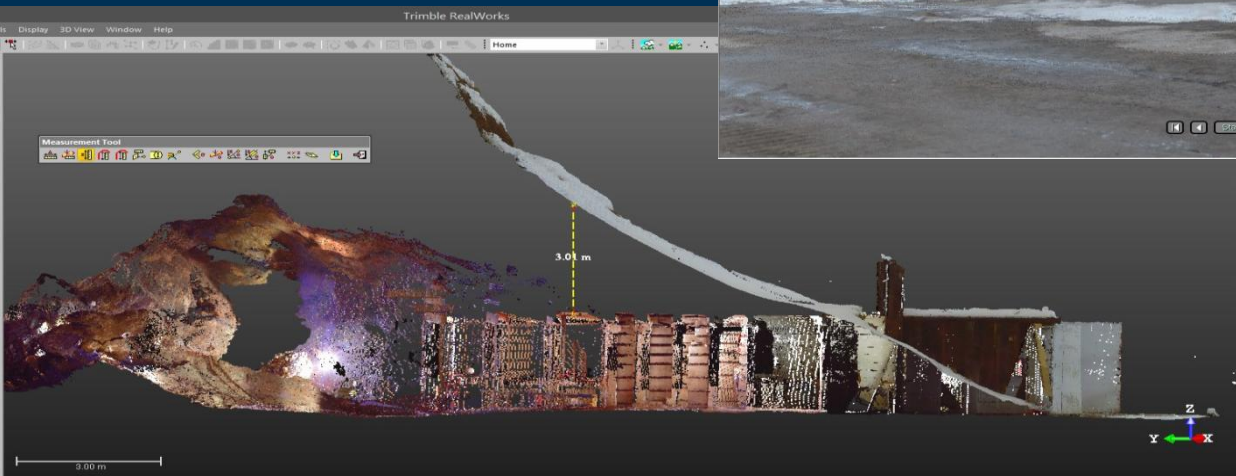
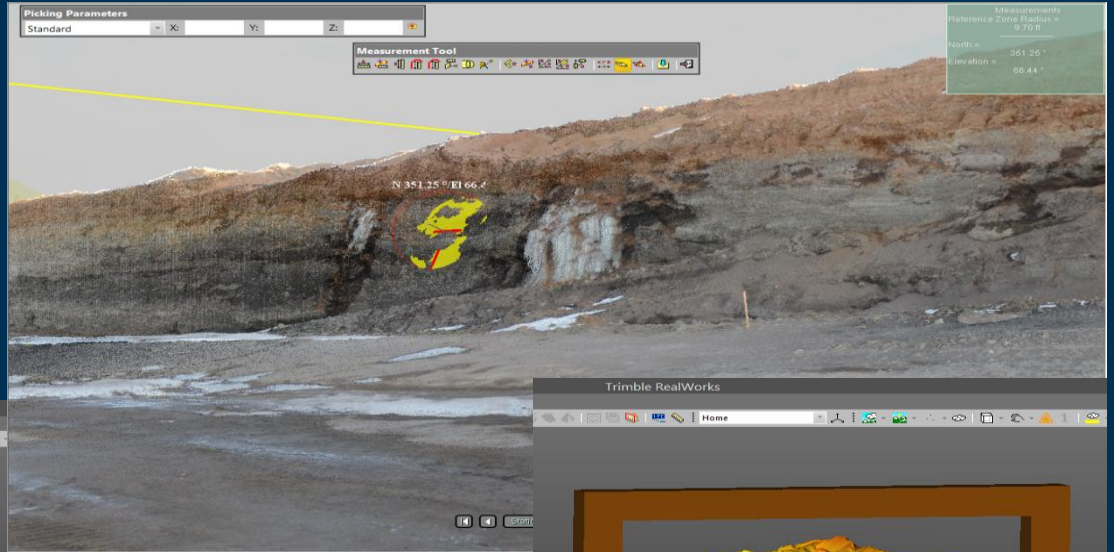
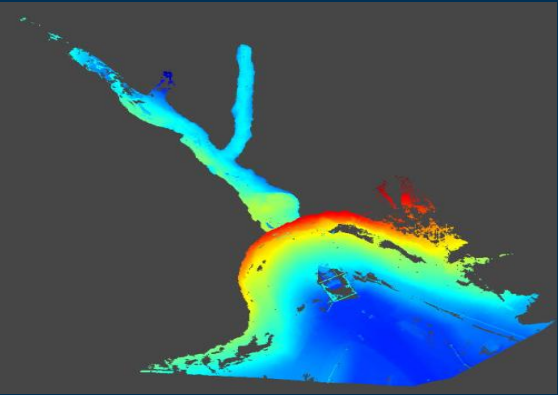

# Facilities\* and Modeling

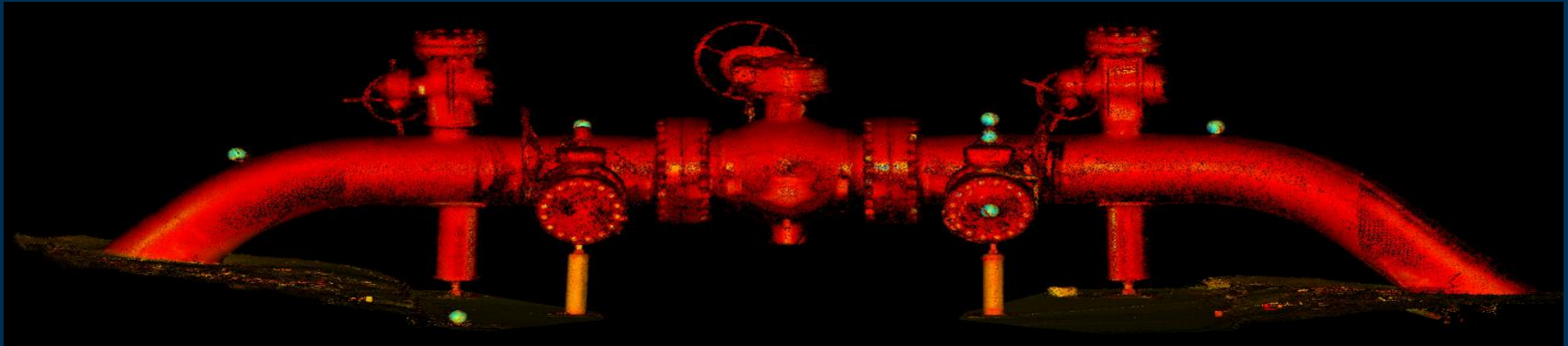
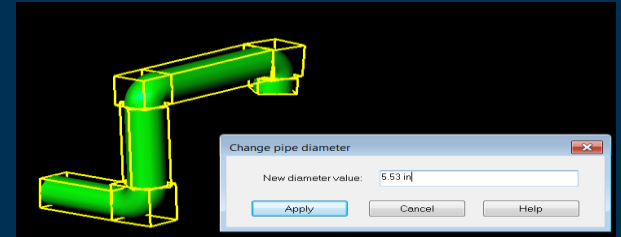
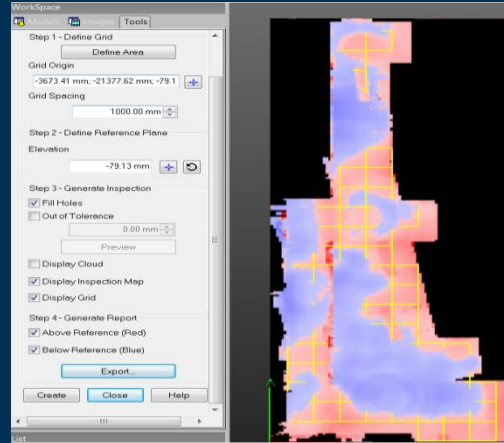
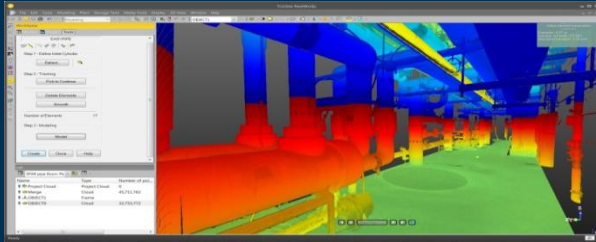

# Facilities Modeling

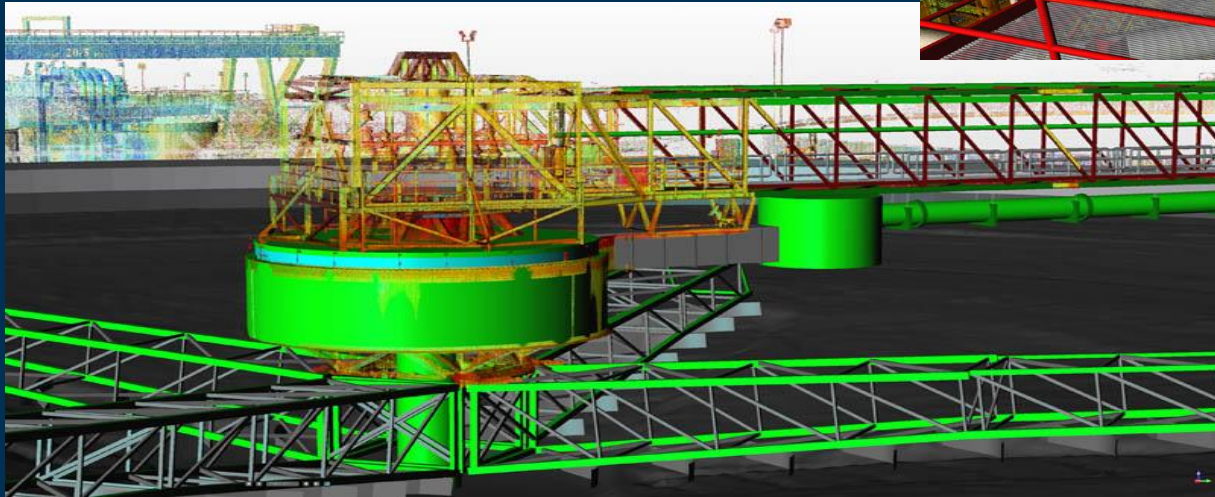
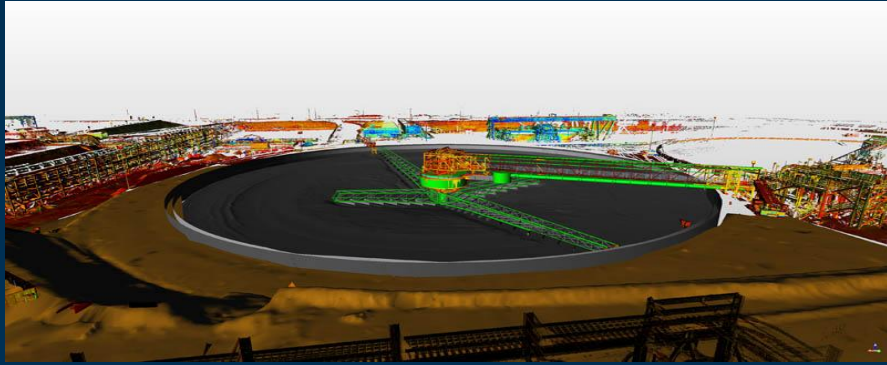

# Inspection and Analysis (\*\*\*\*\*)

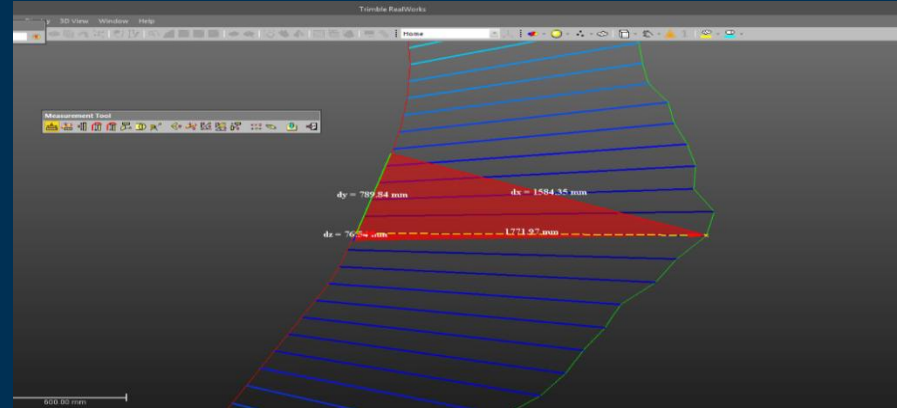
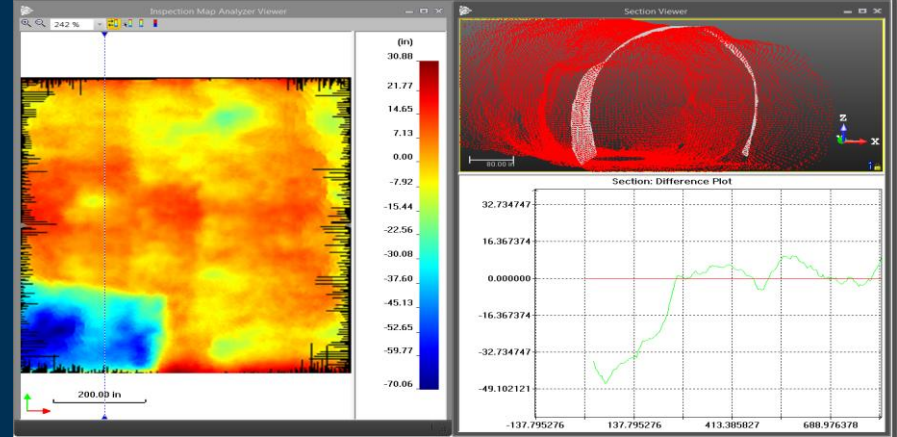
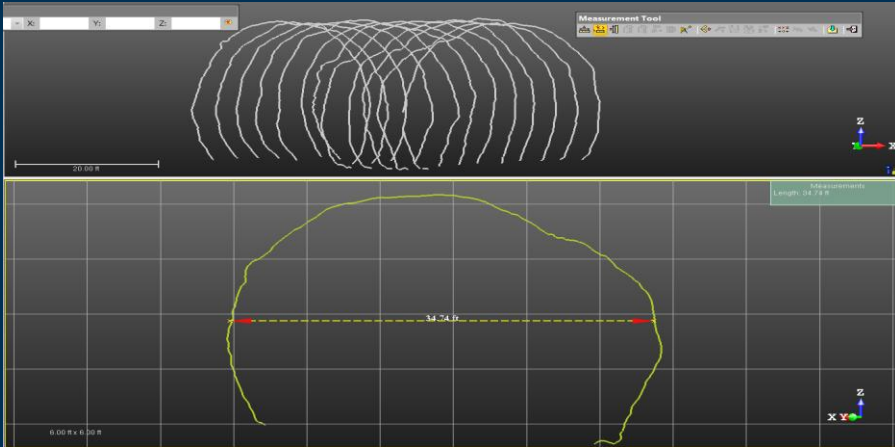
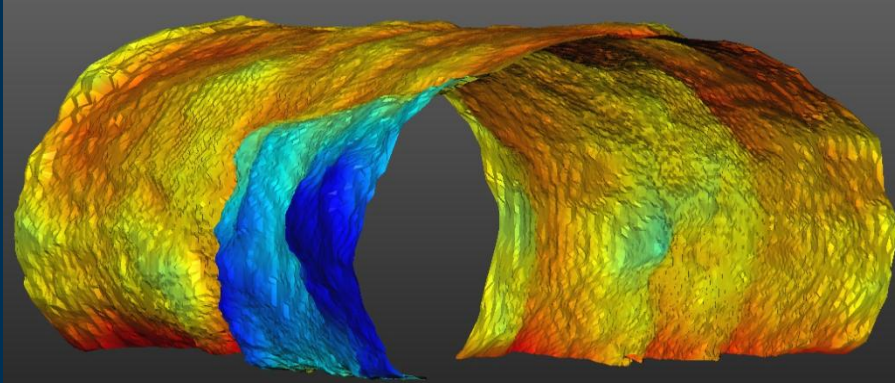

# Semi Automated Parasite Removal

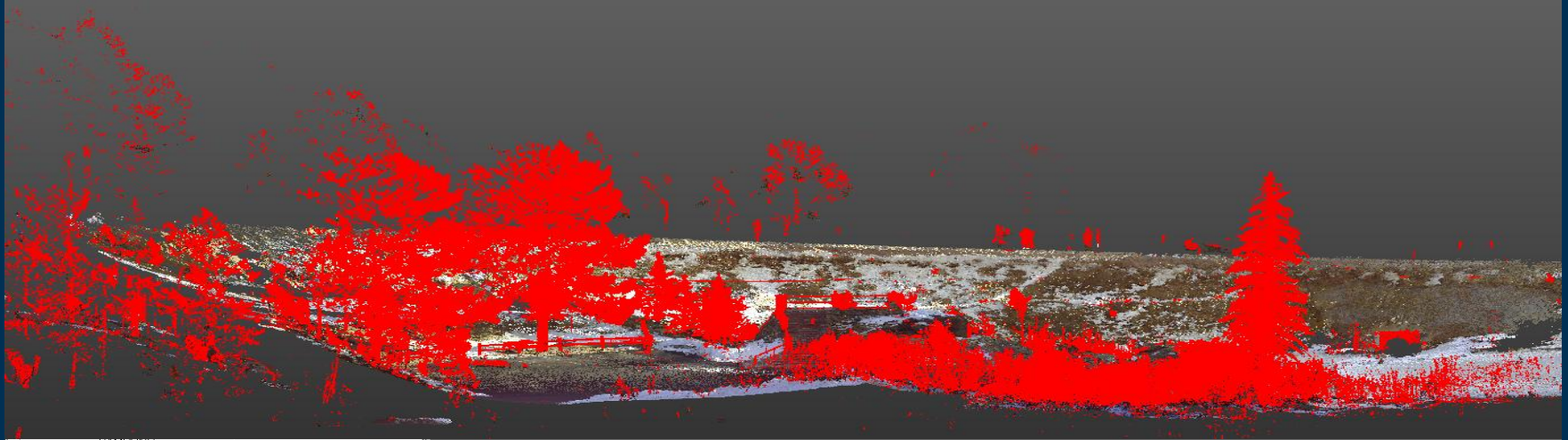

SAMPLING

Topography-Based Sampling

Display Unwanted Points (Red)

Resolution: 0.66 ft

Vertical Filtering Tolerance: - +

Only Wanted Erase Unwanted

Initial: 11 877 918 Points

Remaining: 5 695 737 Points

Create Close Help

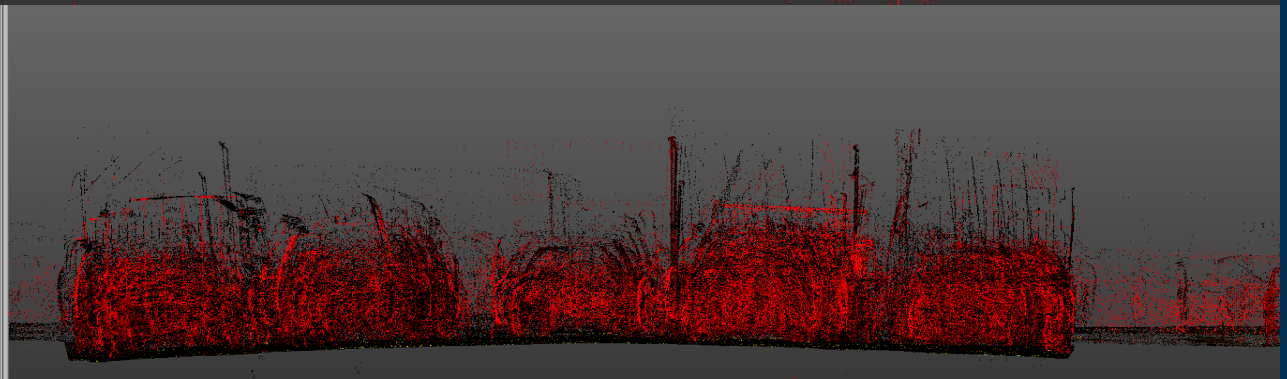

# Volumes, Contours and Surfaces

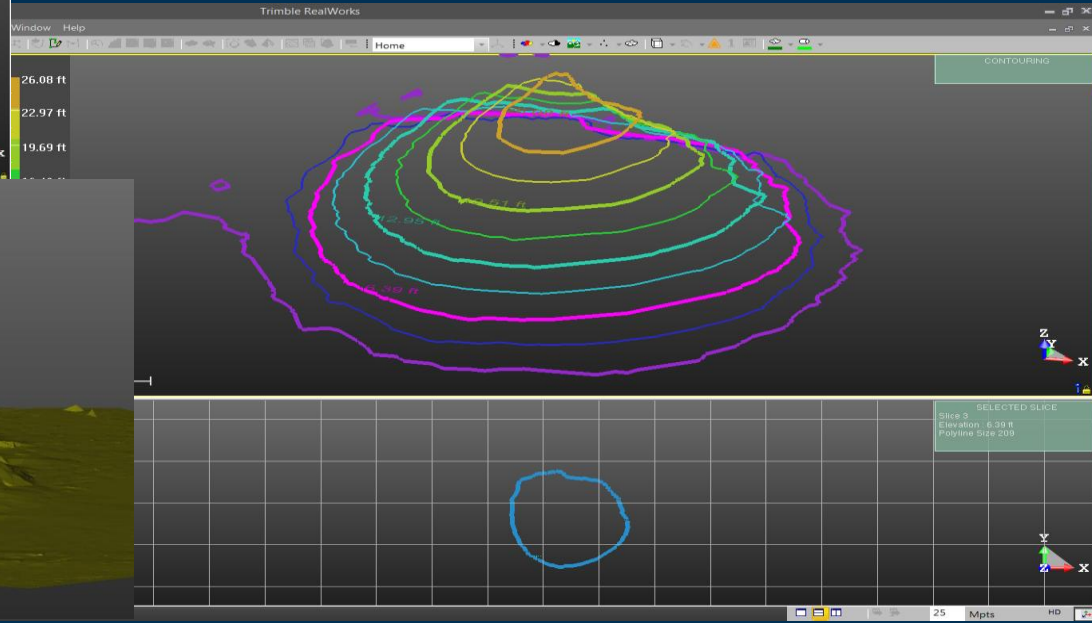
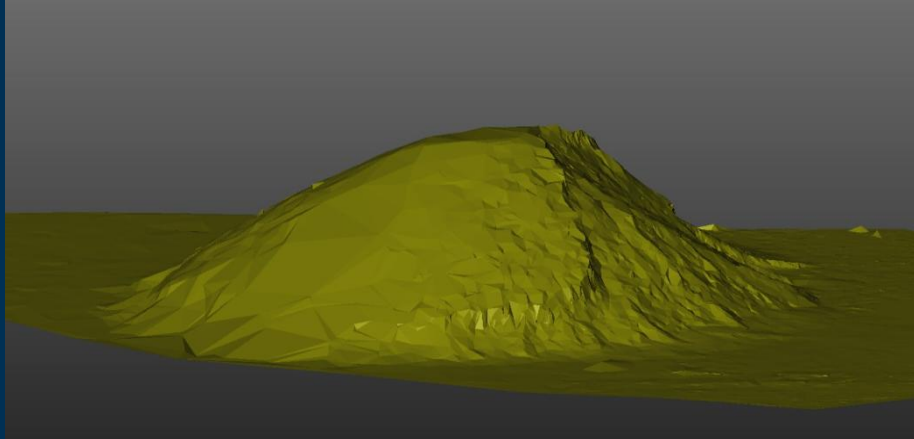
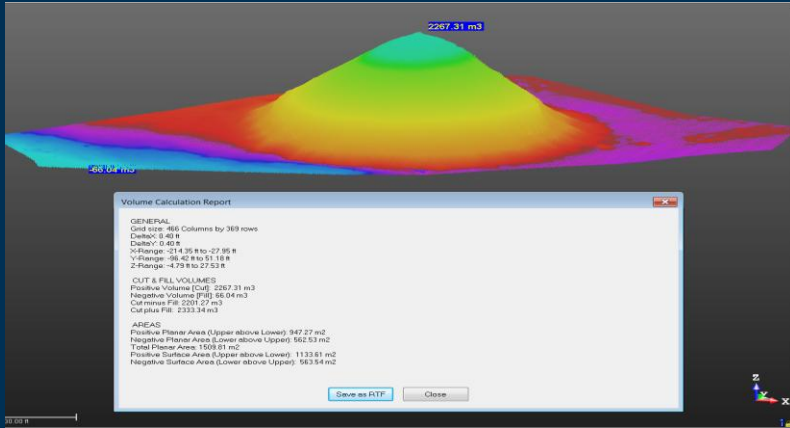

# Powerful Visualization\*

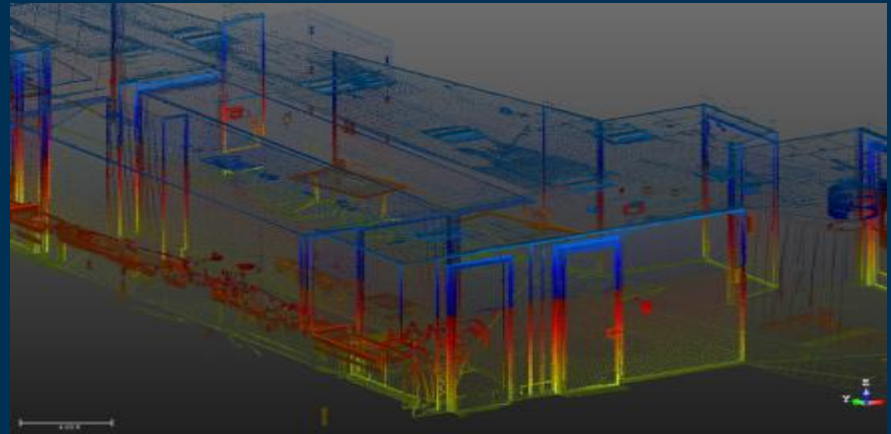
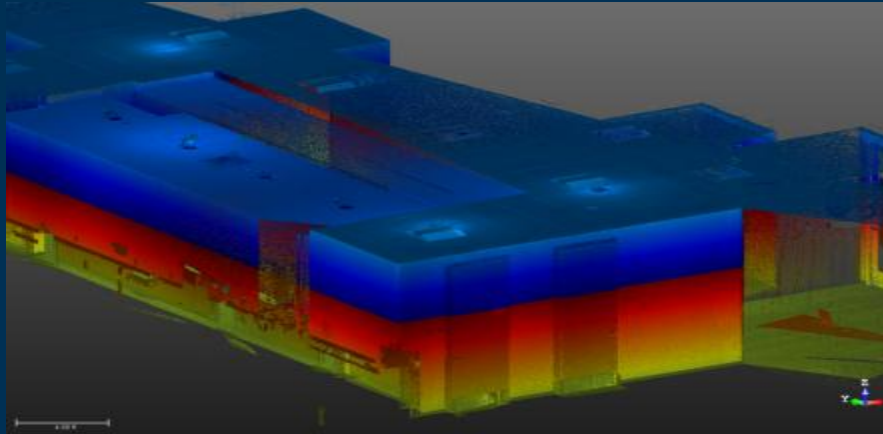
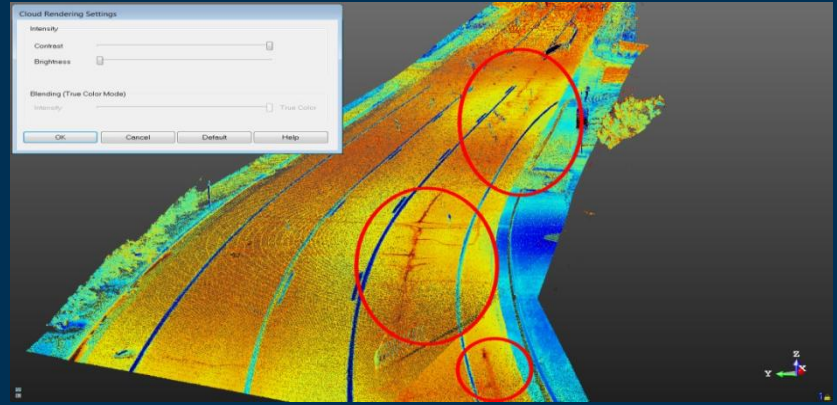
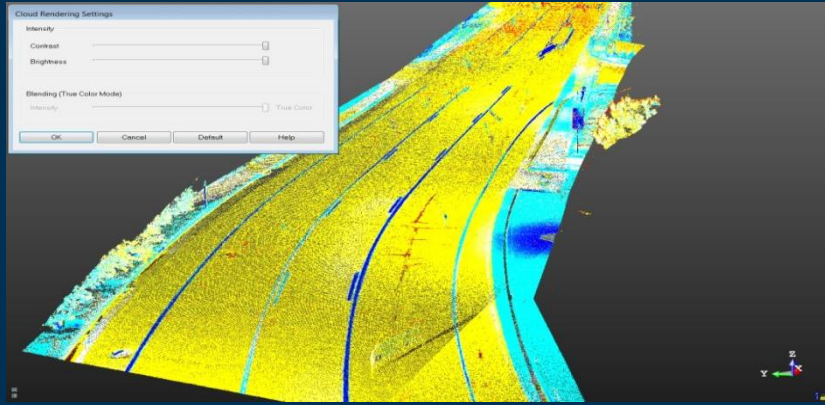

# Media and Sharing

Westminster Castle

INFO  
2/29/2013  
LINKS  
Trimble 3D  
Laser Scanning

Station: [Station name] | Filter register

Tribble Scan Explorer - Westminster Castle / New\_Project\_Scan\_008 / Scan 22



- New\_Group (2)
- New\_Project\_Scan\_004 Scan 18 43 Mpa
- New\_Project\_Scan\_005 Scan 19 43 Mpa
- New\_Project\_Scan\_006 Scan 20 43 Mpa
- New\_Project\_Scan\_007 Scan 21 43 Mpa
- New\_Project\_Scan\_008 Scan 22 43 Mpa
- New\_Project\_Scan\_009 Scan 23 43 Mpa



VIDEO

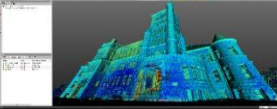

IMAGE



Trimble

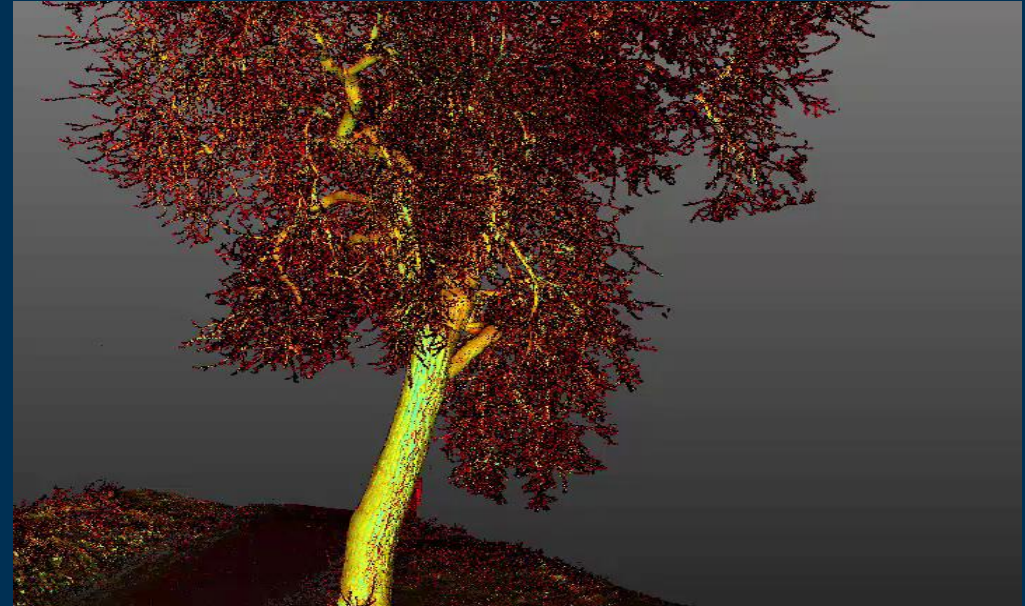

# Virtual Survey – Feature Coding

The image displays a software interface for virtual surveying, divided into several key components:

- FEATURE SET CREATION Panel:** Located on the left, this panel allows users to define feature points. It includes fields for Prefix, Index (set to 1), and Point coordinates (126456.10 ft, 705688.85 ft, 5425.48 ft). A Feature Code Library dropdown is set to 'ALTA', and the Feature Code is 'BC'. The Set Display Mode is 'Points Only', and the Closed Feature Set checkbox is unchecked. At the bottom, it indicates '1 Feature Points' and provides 'Create', 'Close', and 'Help' buttons.
- Picking Parameters Panel:** Located at the top of the 3D view, it shows the current picking mode as 'Standard' and displays the coordinates of the selected point: X: 126454.02, Y: 705681.48, Z: 5425.48 ft.
- 3D Point Cloud View:** The central area shows a 3D point cloud of a structure. A red 'X' icon is overlaid on a point, indicating it has been selected.
- Scan Explorer for RealWorks Panel:** Located on the right, this panel shows a 2D aerial scan of the same area. A yellow text label '126400.02 ft; 705406.22 ft; 5429.36 ft' is overlaid on the scan, corresponding to the selected point. The panel includes a toolbar with various tools and a small inset showing a top-down view of the point cloud.

# Trimble Business Center Office Solution



Complete Survey and Construction  
Office Software Enabling Field to  
Finish Workflows with Confidence



# Trimble Business Center - Positioned as a Data Hub

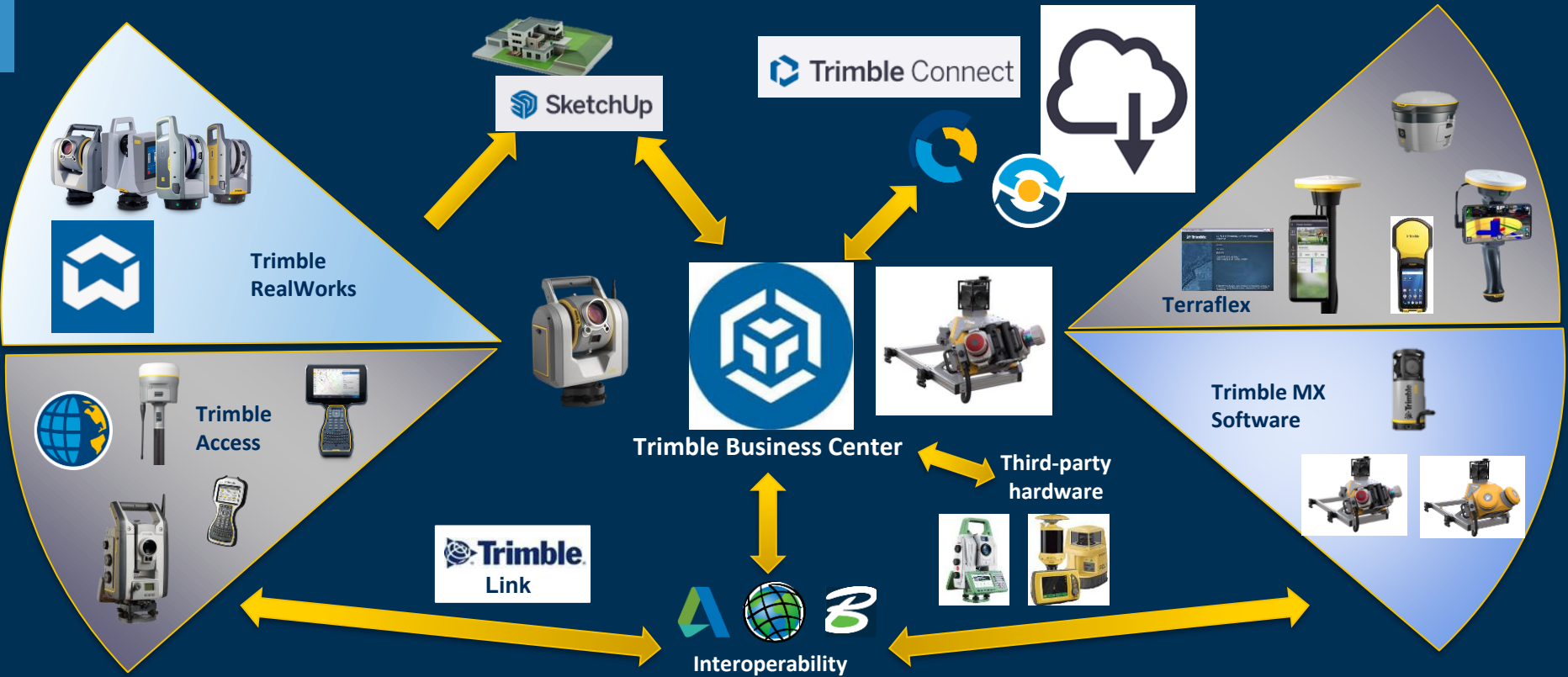



# What can TBC do for Laser Scanning?

Dedicated and **evolving** Pointcloud module + use of Pointcloud in other modules such as Tunnels, Surfaces, CAD, Mobile Mapping etc...

- Registration, Georeferencing **with scale factor** applied to pointcloud (unique)
- Classification (AI (your own classes), indoor, outdoor, tunnel etc...), Sampling, Regions, Cutting Plane
- Extraction (tree, pole, sign, manhole, lines, user defined geometry)
- Orthophoto, rectified images etc....
- Inspections to scans or 3D object
- Surfaces, Feature coding, Drafting
- Various exports and reports
- And many more



# Increased Productivity for Point Clouds in TBC



Linear feature extraction turns data into 3D CAD information

- Curb + gutter - template-based approach
- Overhead lines - power lines, cables, high-tension

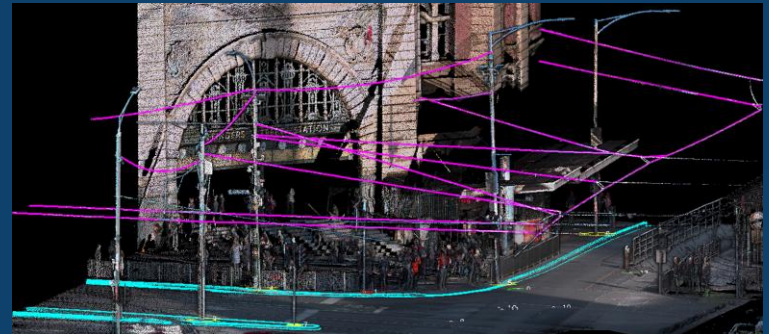
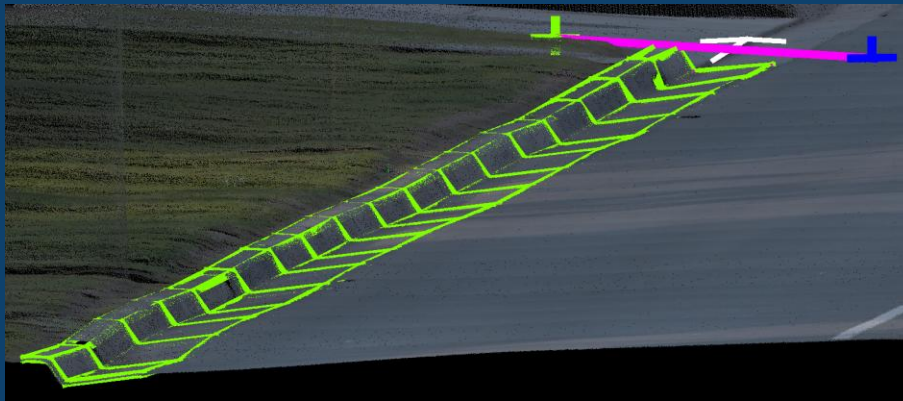
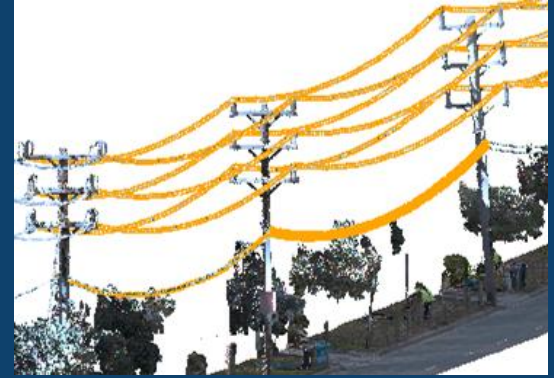

# Increased Productivity for Point Clouds in TBC



Virtual topo in the office with speed

- Measure codes mode added to Create Point command
- Add existing code groups or build your own
- Assign feature codes with a single-click
- Works in combination with CAD Command Line

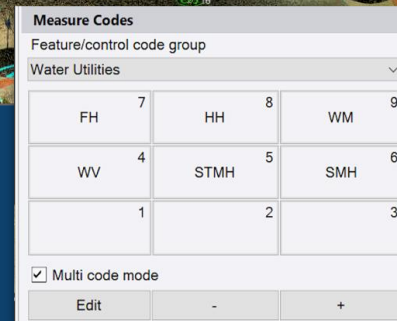
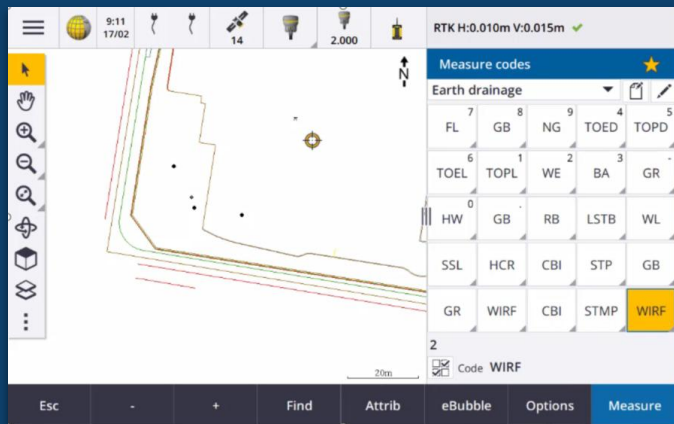
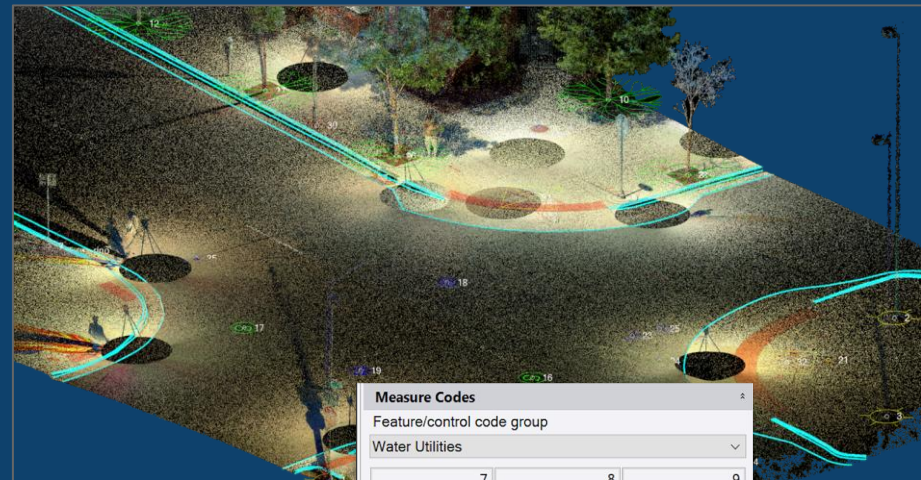

# Building with and for TBC

Quick, professional and customizable building plans



- The Plugin for Trimble Business Center for a quick, easy and professional CAD creation of floor plans, sections, elevations and 3D models out of your scanning data.
- **All in ONE:** CAD, point clouds, scans, total station data, GNSS, digital level, laser scanner, drone, etc in a SINGLE software. **No additional software needed!**
- **Customizable:** Supporting different formats for your deliverables depending on customer´s or project´s requirements. Layers, texts, colors, paper plans, etc.
- **Quick:** Drawing time reduction of **up to 70%** compared with other workflows.
- **Easy:** Special creation forms for building elements with optimized and automatized processes.

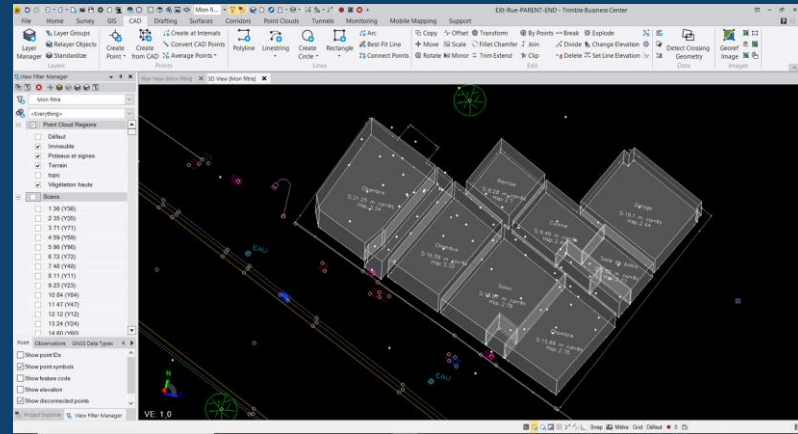



# Verticals such as Tunnelling, Roothing etc. with TBC

Complete office software for tunnel/road survey and construction professionals

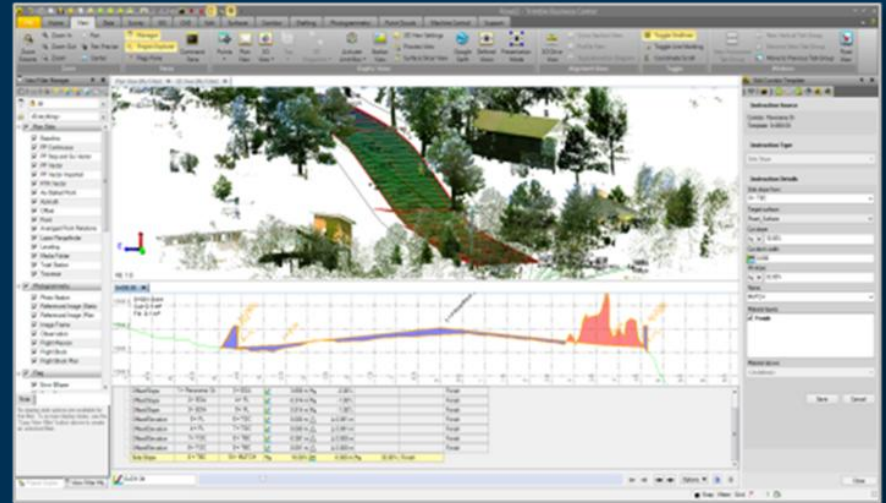
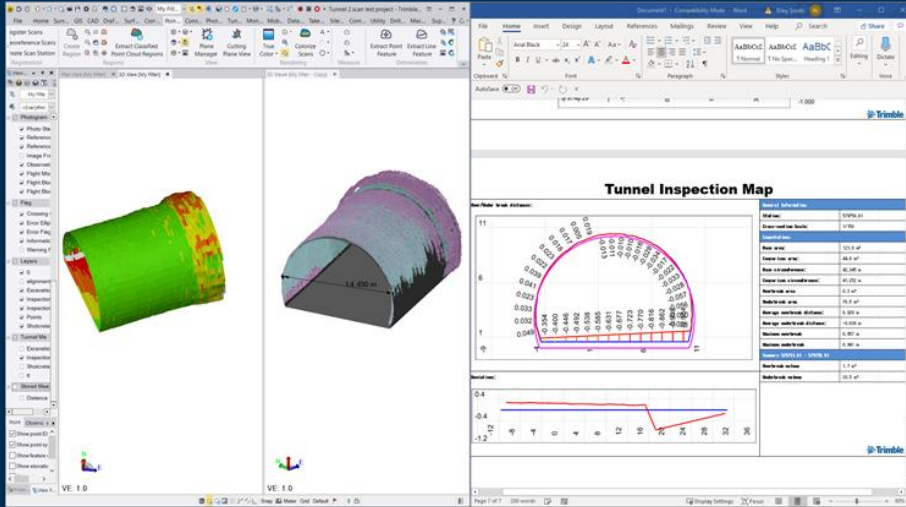

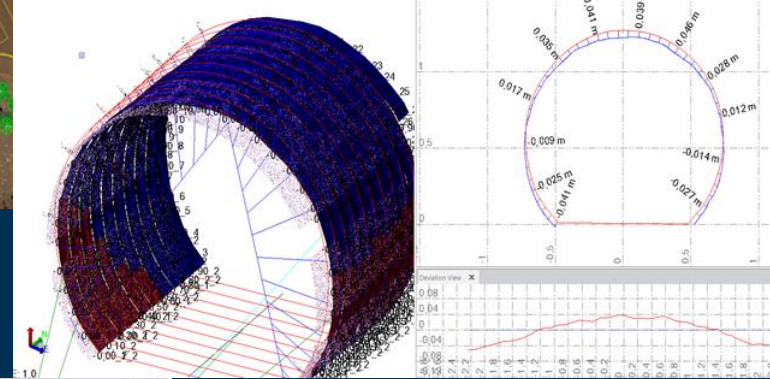
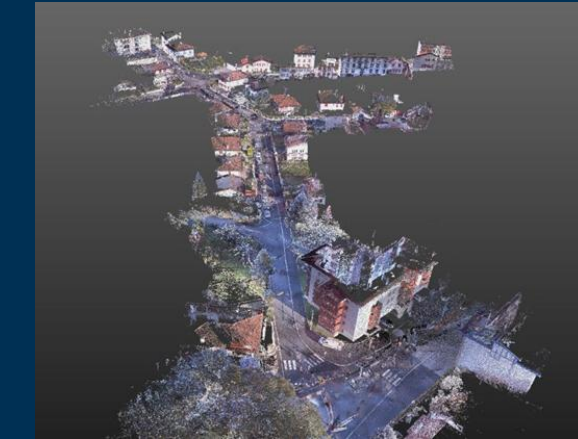
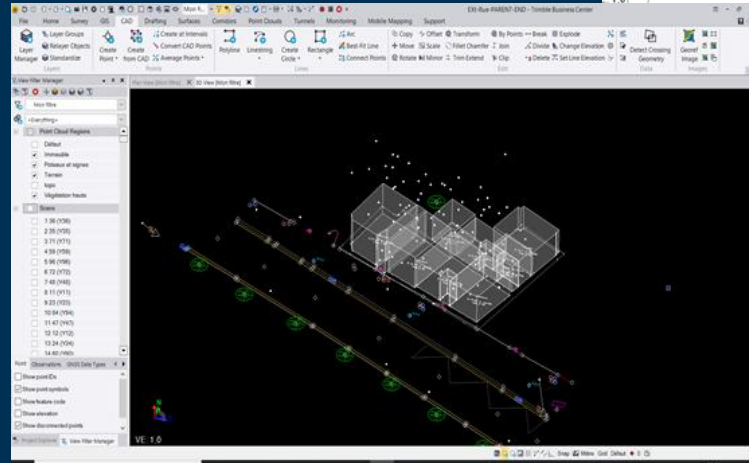
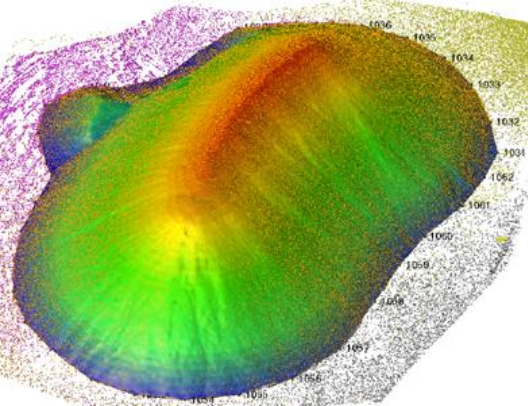

# X-series data survey scanning workflow within TBC

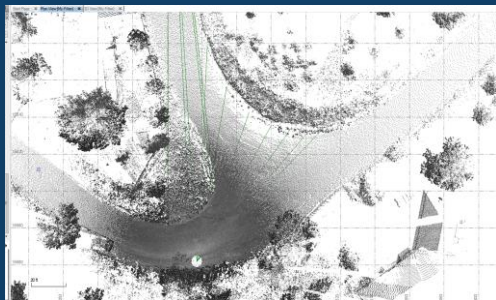

1. Import Data

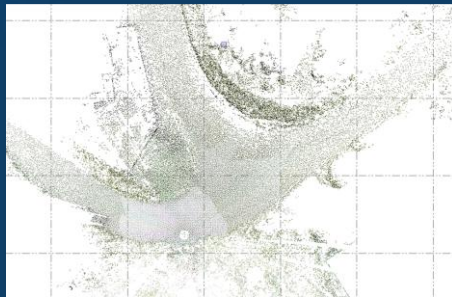

2. Point Cloud Sampling

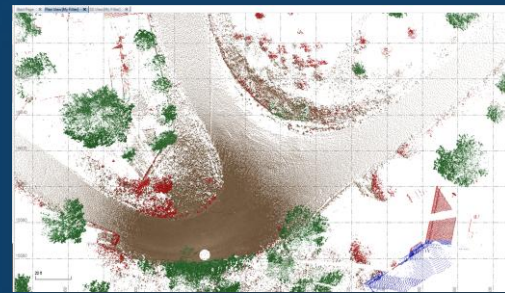

3. Auto Classify Regions

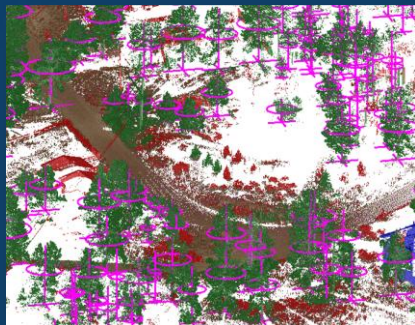

4. Extract Features



5. Draft + Label Geometry  
(measure codes)

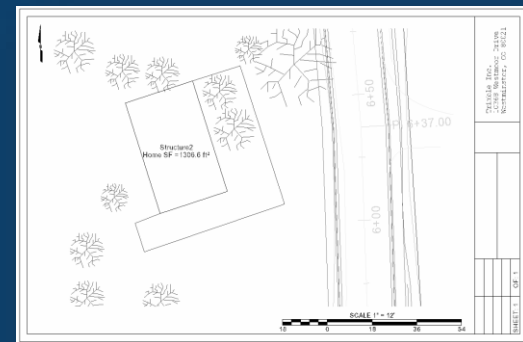

6. Generate Deliverables / Plan Set

# X-series data preparation workflow within TBC

1. Import Data

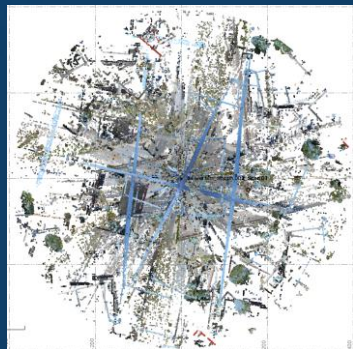

2. Scan registration + Georeference



3. Point Cloud Sampling

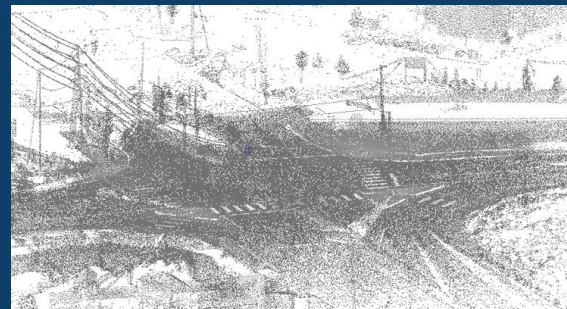

4. Auto Classify Regions

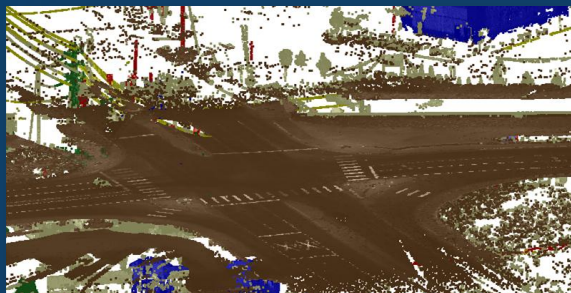

5. Point Cloud Export

**LAS**      **PTX**  
LAZ  
**POD**      **RCP**  
PTS  
**TDX**      **e57**

6. Use in third-party software



# Trimble Laser Scanning

## 3D LASER SCANNING SOLUTIONS

# 04

## Highlights & Applications



# Trimble X-series System architecture

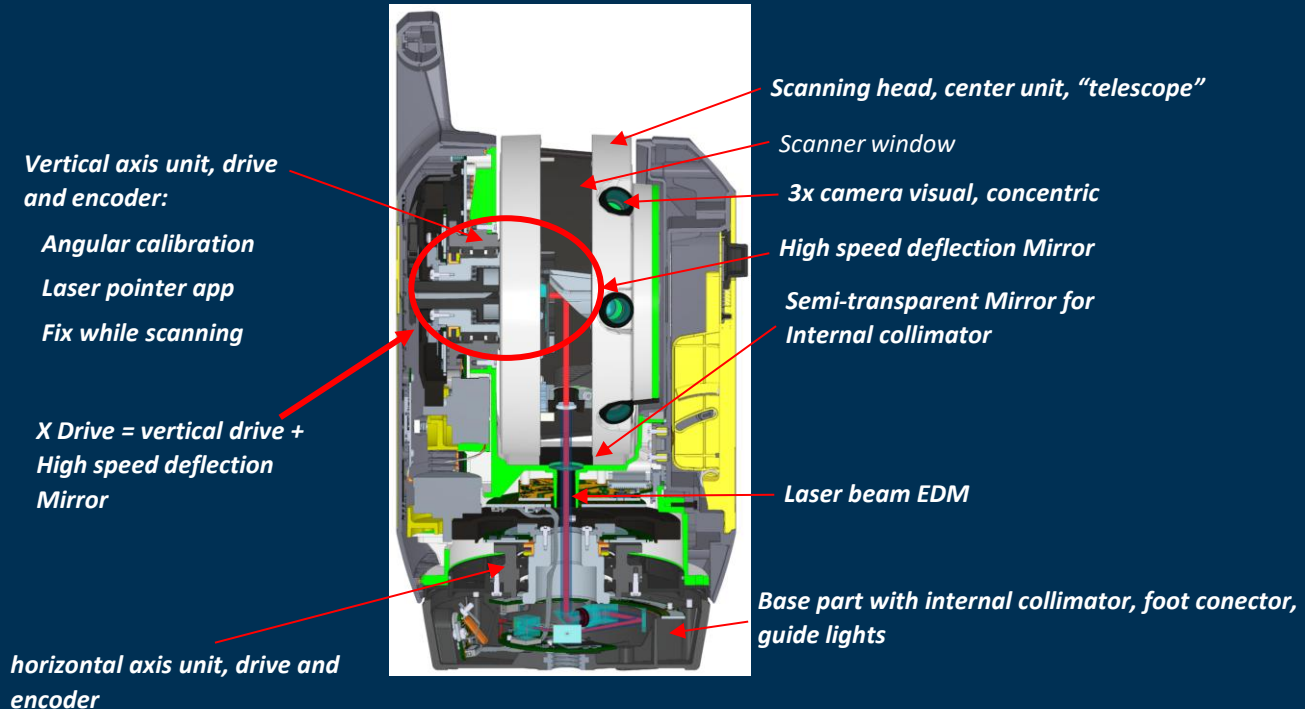

# Deep Dive Into Trimble X Drive

## Increased Tilt Range for 3" survey grade leveling accuracy

- Tilt range has been increased from  $\pm 5^\circ$  to  $\pm 10^\circ$  for survey grade accuracy of  $< 3''$  for upright and upside down scans.

Survey grade level data provides proof against survey truth. Self-Leveling will ensure accuracy you can trust without targets or extra control on topographic surveys, floor flatness applications or when monitoring the verticality of columns or walls during construction. For example, the verticality of a 10 m building will have an error of just 0.14 mm and the floor flatness of a 20 m floor will have an error of just 0.3 mm. Without survey grade leveling, some scanners can have  $> 8\text{mm}$  error at 10 m and  $> 17\text{ mm}$  error at 20m.

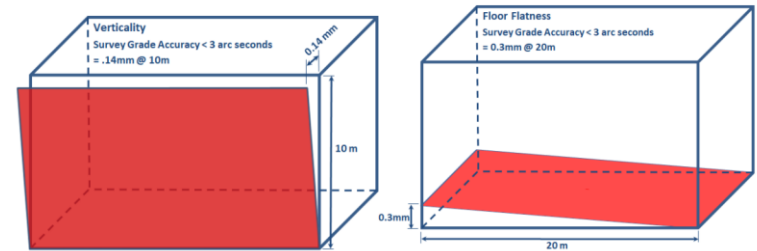

## LED Levelling Guide on/off option

- New leveling guide to assist with the adjustment of tripod legs to ensure instrument is leveled within range of  $\pm 10^\circ$



# Trimble X9 + Perspective in a nutshell

## The 3 A's

Auto Full Registration  
Auto Calibration  
Auto Leveling

## Ultra Efficient Full in Field Registration

Labels, Annotations, Measurements  
Registration bundle refinement & Georeferencing  
Data export and reporting in the field  
Astonishing 3" leveling accuracy

## Innovative & Powerful

Laser Pointer  
High Sensitivity scanning mode  
Full data redundancy onboard and on SD

## Simple

Reliable field workflow suitable for all users  
Intuitive yet powerful Perspective SW  
Compact, lightweight, Silent & with a Handle!!!  
Silentwith a Handle!!!

## Flexible **Operations** and syncing

Tablet  
Phone  
One Button Workflow  
Cable connection

## Robust and Always perfectly Ready

IP55 rating and -20°C - +50°C  
2 years warranty  
Diagnostic + Seamless Field Calibration report



 Trimble.

# SX12



# SX12 Ecosystem

Trimble Access on  
Windows Controllers



Trimble Business Center  
office software



Trimble RealWorks  
office software

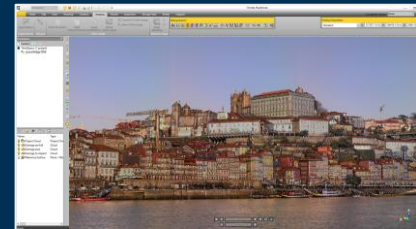

# Specs at a Glance

High accuracy total station, high quality scanner

- 1" angular accuracy
- 1.5 mm scan range noise at 200 m
- 14 mm diameter EDM laser spot at 100 m

Quick data capture, even at long range

- 26.6 kHz scan measurement rate, up to 600 m
- 1.6 s total station measuring time in Prism mode
- 1.2 s total station measuring time in DR mode

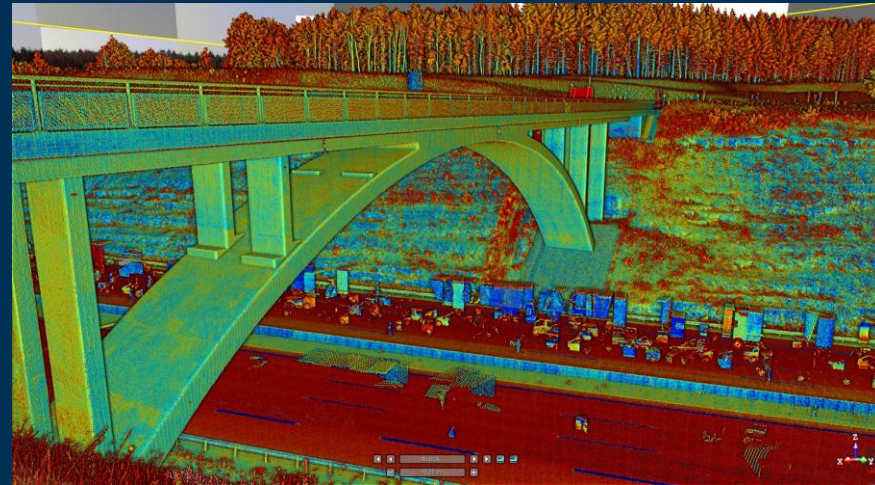

# SX12 Applications

**Every day  
Everywhere  
Every job**

- Open Pit Mine
- Underground Mine
- Tunneling
- Dimensional Control
- Tank Inspection
- Infrastructure
- Boundary
- Road & Corridor
- Power Lines
- Volumetric
- Utilities
- Topo & Stakeout
- As-Built
- Construction



# Trimble Lightning 3DM Band Scanning

- Rotating Deflection Prism
- Captures bands or swaths of points as the instrument rotates
- Scan data registered by survey stations

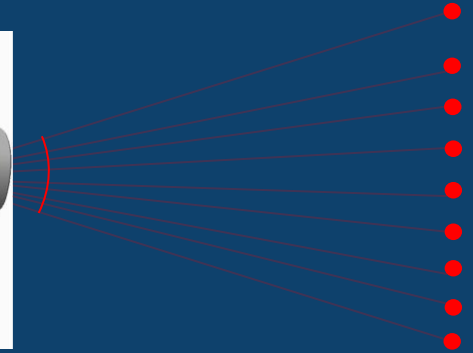
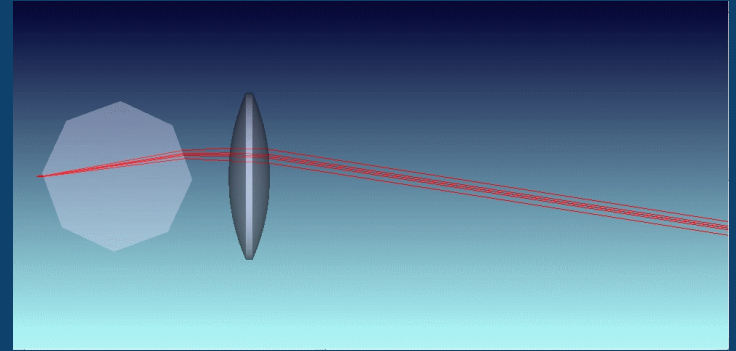

# VISION System

## 4 Integrated Cameras

- 3 Forward facing
  - Navigation and Documentation
- Plummet camera
  - Station setup and Documentation



Time: 11:32:38 AM	Date: 1/4/2021
Sighting: -0°00'00"	Trunnion: 0°00'01" Compensator: On
Station: BP 1 SO 454045	Code: EKN5
Height (SX bottom notch): 1.688m	
Temperature: 22.0°C	Pressure: 989.40mbar PPM: 8



# Key Takeaways

---

High accuracy total station  
High quality scan data



**Every day**

Vivid, eye-safe laser pointer



**Everywhere**

Complete, integrated System



**Every job**



# SX12 Green Focusable Laser Pointer

Important for stake out, set out, control

## SX12 Laser Pointer Specifications

Spot Size - full width half maximum (FWHM)	1.3 to 50m.....3 mm ± 1 mm At 100m.....6 mm ± 1 mm At 150m.....9 mm ± 1 mm
Autofocus 1m- ∞	YES Constant (3 mm ± 1 mm) at range < 50 m
Color, Wavelength	Green, 520 nm
Laser Class	Laser Class 1M



# SX12 Data Collectors with Trimble Access 2025

- TSC7
- TSC5
- T10X

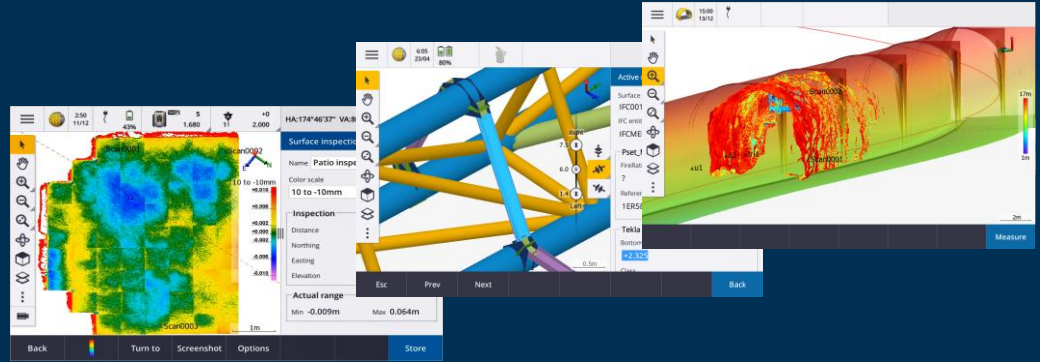

# Trimble Access

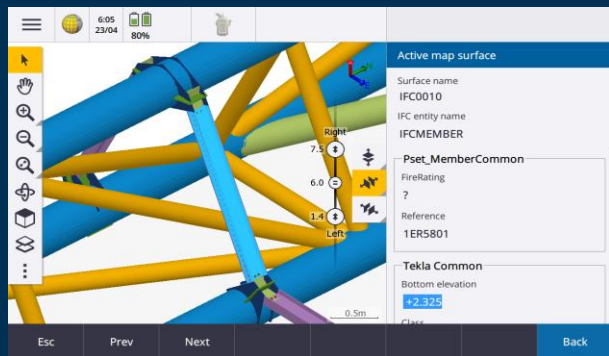
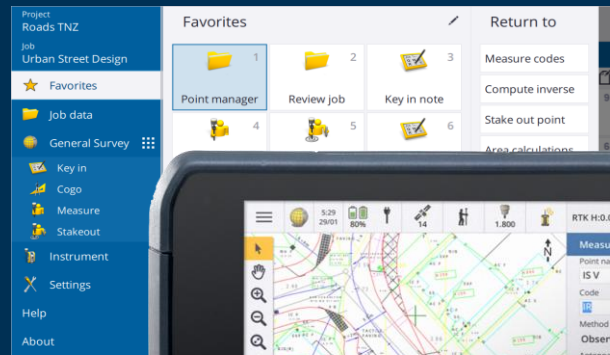
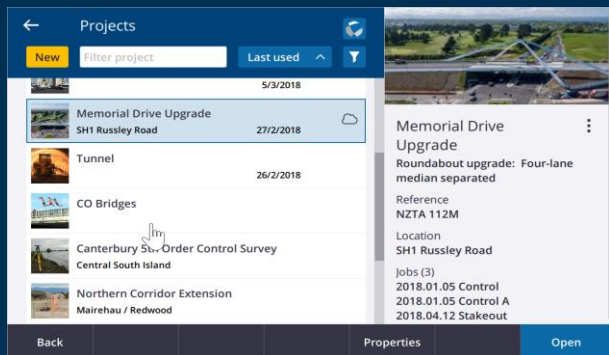



## Support IFC 4.3

IFC models can be used several ways:

- Model visualization
- Clash detection/inspection
- Attributes reviews
- Stake out
  - Points
  - Polylines
  - Alignments
- Cogo
- Surfaces inspection

Model can be georeferenced directly in the field



# IFC + SX12 Video + Scan data

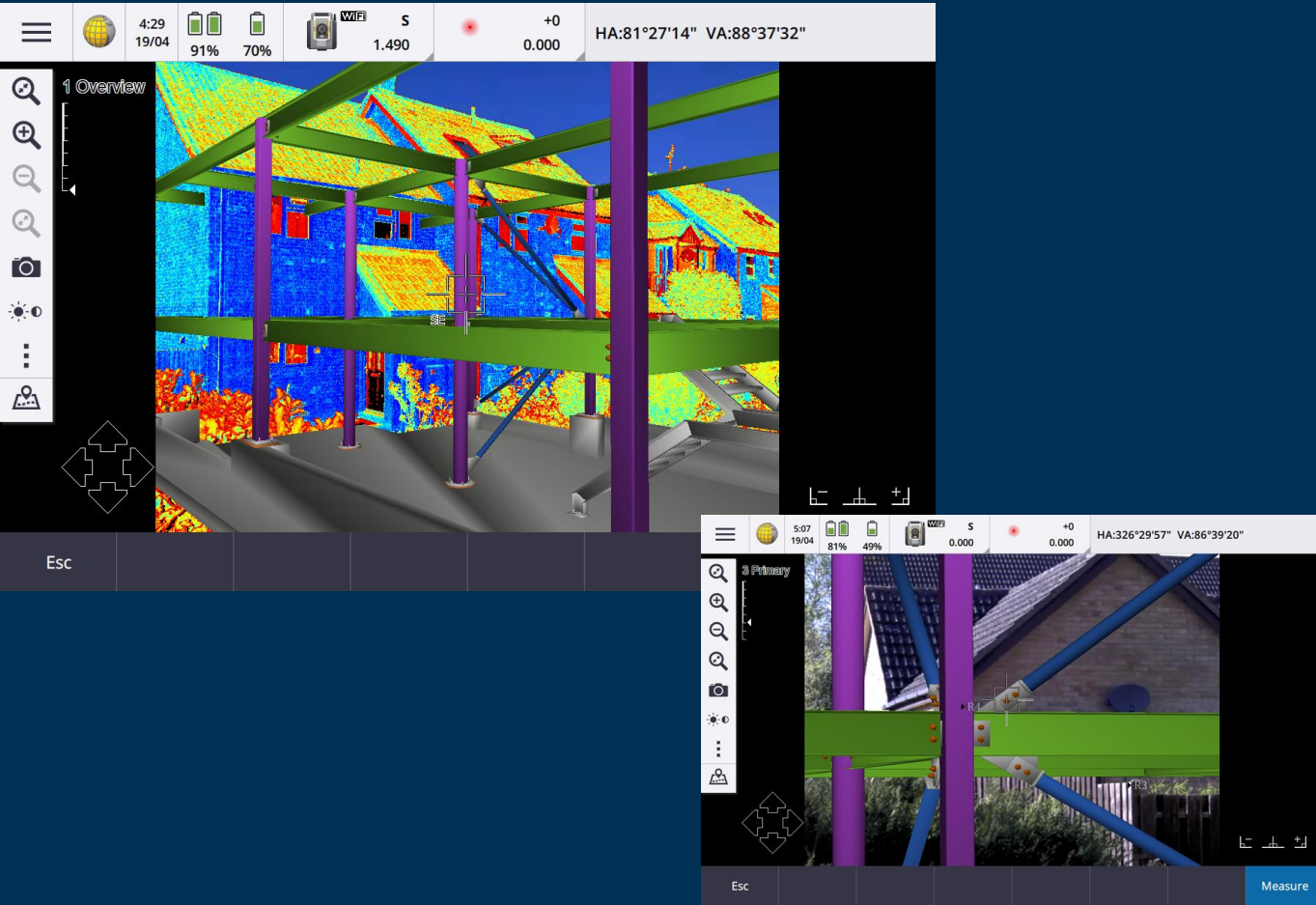

AR Viewer vous permet d'interagir avec vos données spatiales dans le contexte du monde réel

Les informations de position et d'orientation sont fournies par le récepteur GNSS IMU connecté (Trimble R12i) ou la mise en station de la Trimble SX12

informations de position et d'orientation sont fournies par le récepteur GNSS IMU connecté ou la configuration de la station SX12



# SX Total Station Support - Visual Inspection

- Benefit from advanced camera system to take images with high quality.
- Optionally enable image taking per target and per round and thus document changes on surfaces and targets
- Visualize and compare images at new visual inspection site at T4D Web
- Images are shown next to graphs and allow users for easy visual inspection of any movements or displacements.

The screenshot displays the Trimble 4D Control web interface. The top navigation bar includes 'Home', 'Sensors', and 'Terrain View'. The main dashboard is titled 'Charts and Analysis' and features a grid of interactive tiles. A 'Visual Inspection' menu is open on the left, highlighting the 'Visual Inspection' option. The dashboard tiles include:

- Sensors:** Configure sensor data to be displayed in the web interface, view sensor properties, latest sensor readings and current sensor state.
- Data Entry:** Input observational data for your physical sensor. Check datasets for correct data entry or use T4D data templates for office data entry. Connect via file to sensors for data import.
- Sensor Groups:** Create sensor groups to refer to groups of sensors or to create representative calculation sensors.
- Map:** View sensor location, data and state on an interactive map.
- Webcams:** View webcams linked to the project.
- Custom Views:** View sensor locations, data and state on user selected images, with data updates at specified time intervals.
- Charts:** View the selected data series of a single sensor in a simple chart.
- Scatter Plot:** Visualize and compare positional displacement over time for a particular sensor within two different planes.
- Analysis:** View selected data series of multiple sensors in a complex chart for graphically analyze the structural behavior.
- Composite Views:** Create the main view view composite views by combining data views.
- Visual Inspection:** Visually inspect the target images of a single sensor.
- Alarms:** Create Warning and Alarm Conditions against the data series and thresholds, with notifications being issued if the event that Warning or Alarm Conditions is met.
- Logs:** Record activities and trends of interest either manually or automatically.
- System Status:** Monitor the system health by analyzing sensor data delivery and alarm events. View either the current or historical system status.
- Reports:** Create and manage report schedules.

The footer of the interface includes the text: 'Click here to navigate to the Visual Inspection page.', 'Copyright © 2021, Trimble Inc. 6.3.0.0', and 'English (US)'.





# SX12 Mixed Reality with Trimble ACCESS

## Trimble Access AR mode:

- In-field comparison
- More efficient data handling
- Visual inspection with mm accuracy
- Access model attributes
- Layer handling
- Pick entities in the model/easier stake out
- Extract line, point and surface information directly from model

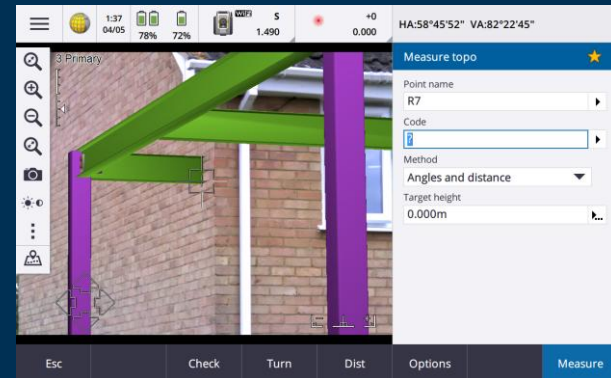
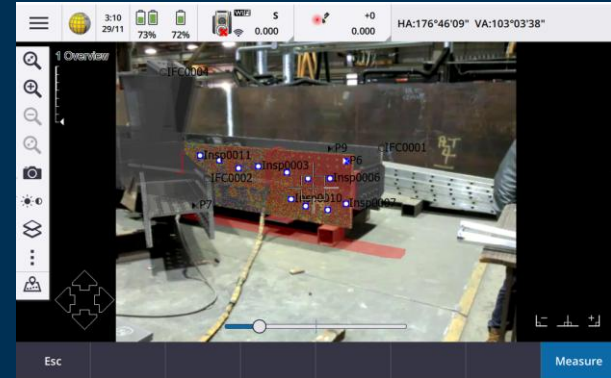

# SX12 for construction with IFC models

## Stakeout Workflow – TBC part:

Prepare the georeferenced IFC in office software

Or orient and scale not-georeferenced model in TBC

Create Points in TBC for stakeout

Send stakeout data as well as the „georeferenced“ IFC model to Trimble Sync Manager (Trimble Connect)

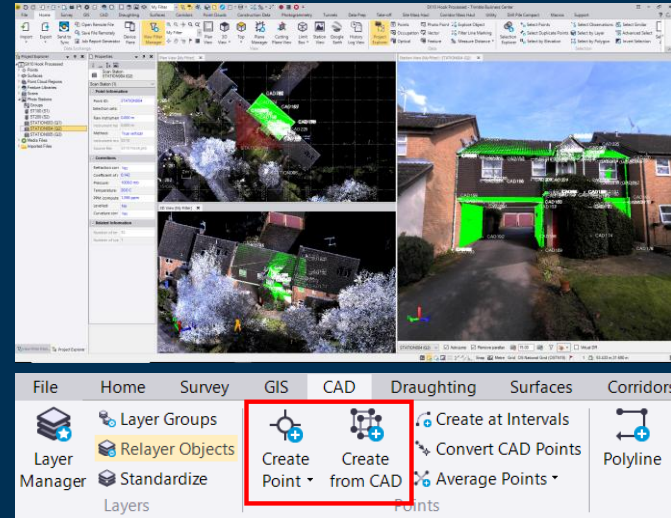



# SX12 for construction with IFC models

## Stakeout Workflow – Access part:

Sync projects with Sync Manager in Trimble Connect

IFC files, control points, stakeout design points (i.e. txt, csv, etc.),  
Create Points in TBC for stakeout

After, IFC model as well as the stakeout point are visible in the Map area

Ready to stakeout with visual real-time background and IFC model from the design

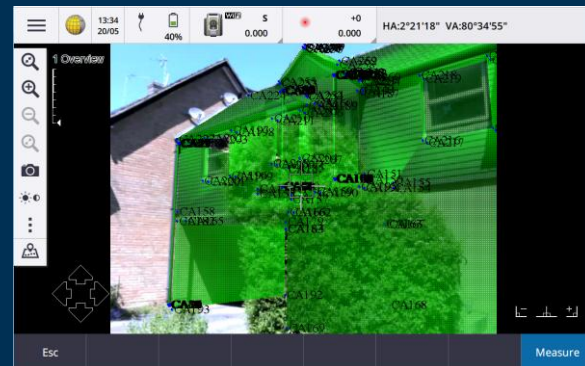
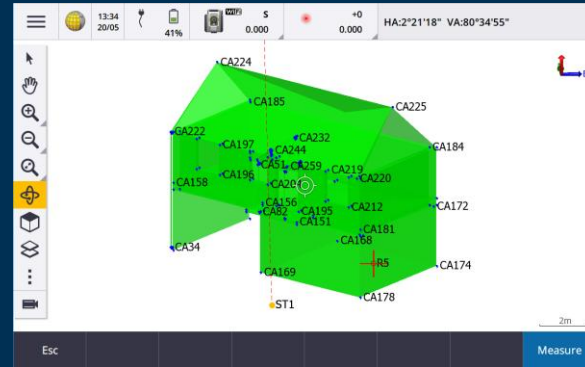



# SX12 for construction with IFC models

## Stakeout Additional Stakeout Elements

– Access part:

Trimble Access allows to stakeout elements that have not been previously defined in the office:

Select points, lines, surfaces **directly from the 3D model**

Use Snap-to toolbar to create additional points based on the model

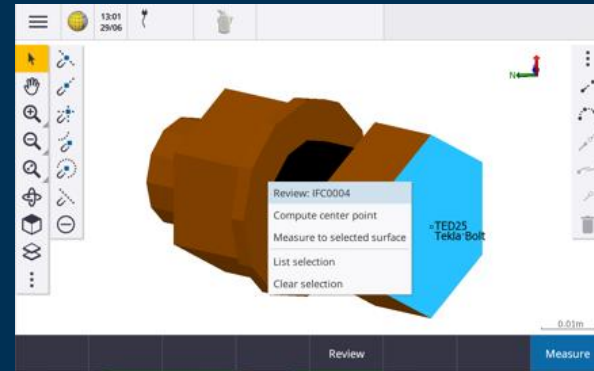
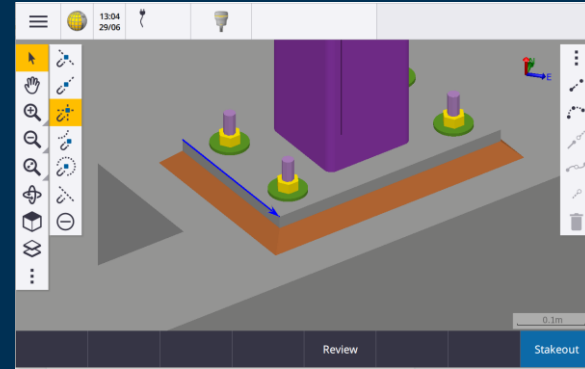

# Create heatmap in the field by comparing scan to model or scan to scan for progress monitoring: floor inspection, wall verticality

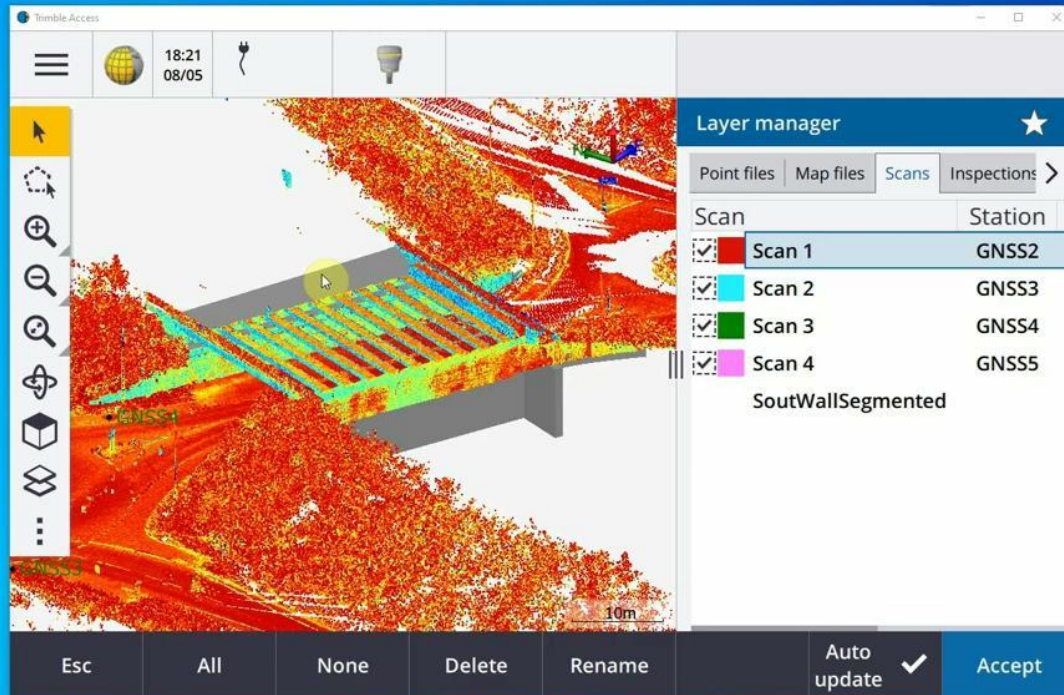

# Send field data to the office for processing and reporting in Trimble Business Center

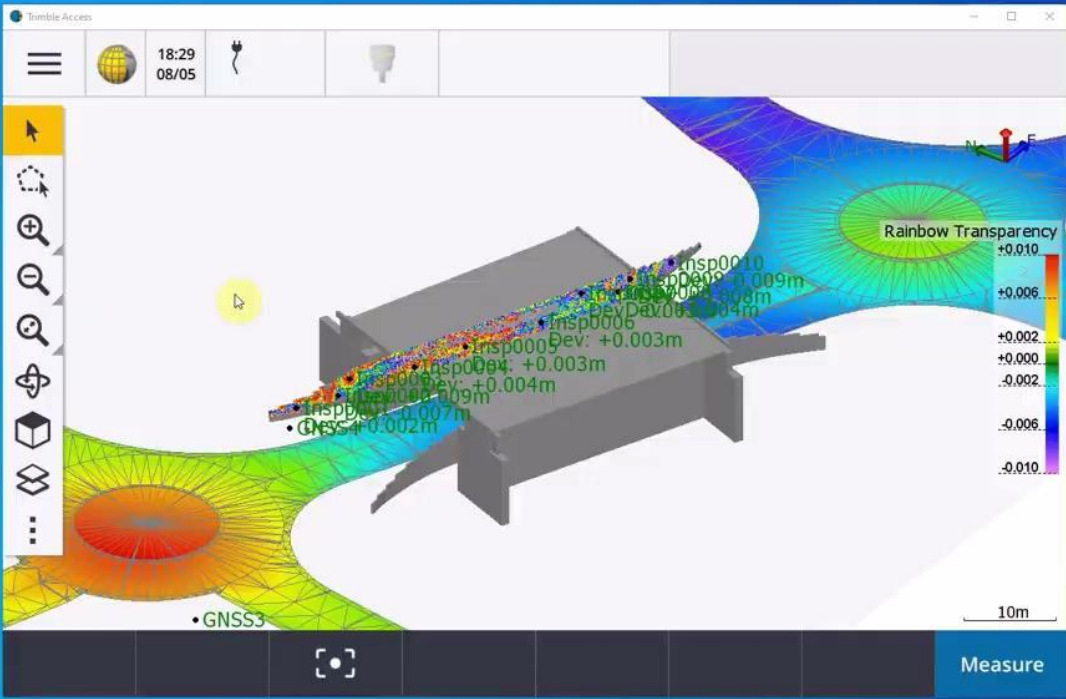

# Fabrication/Inspection with SX12

## Stake out & Inspection

- Model and instrument are aligned with the physical object Inspection
- AR mm capability for visual inspection and better data interpretation
- Display of IFC models in 3D and in real-time video (8 zoom levels)
- Single/digitized points and extracted points
- Prism offsets
- Scan window
- Field inspection (scan-to-surface), inspection map (also in AR)



### Inspection: Wall5

Method	Scan to surface
Reference surface	combined.trb
Selected scans	Wall3
Minimum delta	-0.194
Maximum delta	0.181
Color scale	Rainbow

### Inspection point deviations for: Wall5

Point name	North	East	Elevation	Deviation
Insp0012	303.067	85.323	67.942	0.013
Insp0013	303.256	85.230	67.933	0.022
Insp0014	303.468	85.153	67.953	0.002
Insp0015	302.640	84.462	67.859	0.096
Insp0016	303.370	84.474	67.946	0.009
Insp0017	303.020	84.924	67.945	0.010
Insp0018	302.337	83.532	67.946	0.009
Insp0019	302.973	83.346	67.961	-0.006
Insp0020	302.575	83.809	67.940	0.015

# Office Inspection with TBC and/or TRW

- Trimble Access Object oriented setup
- Analyze & report scan to scan or scan to model
- TA Inspections
  - Heatmaps & pointcloud regions
- TBC Inspections
  - Scan-scan, Scan-3D objects (IFC, TRB, Meshes and surfaces) comparisons
  - Deviation reports

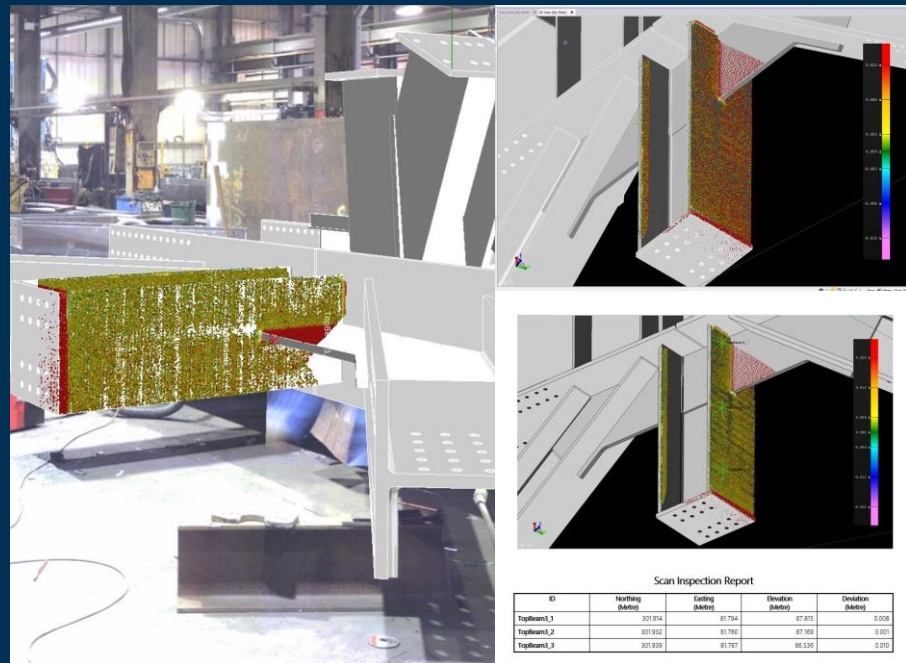

# Trimble SX12 + Trimble Access in a nutshell

## The Best 1" Total Station on the Market

SX12 Lightning 3DM  
High Accuracy Total Station  
High Quality Scanner  
VISION Imagery

## Ultra Efficient Full in Field Registration

Full Survey Workflow  
1,5 mm scan range noise @200m  
8mm EDM laser spot size @50m  
26,6 kHz scan measurement rate up to 600m

## Innovative & Powerful

Green focusable Laser Pointer (3mm @1,3 to 50m):  
Aim, Measure & Mark  
Best Vision System with 4 integrated cameras  
Image Pixel size down to 0,69mm @50m

## Versatile

Every day  
Everywhere  
Every job Handle!!!

## Flexible Operations

Data collection with Trimble Access Modules to  
adapt to your needs  
Process seamlessly with either TBC or TRW  
Share with Trimble Connect

## Robust and Always perfectly Ready

IP55 rating and -20°C - +50°C  
2 years warranty





# Trimble Reality Capture Platform Service

# Trimble Reality Capture Platform Service

## What is TRCPS?



### **TRUST** | Trustworthy storage at scale

Leveraging Microsoft Azure's robust cloud backend, securely store and manage data without losing any accuracy, quality, or fidelity in the cloud.



### **CONNECT** | Maximizing Value

Help anyone get the value out of reality capture data by easily sharing, viewing, and collaborating, all in the web. No specialized software or training required.



### **TRANSFORM** | Trimble Connect

By centralizing reality capture data in Trimble Connect, users get the benefits of the entire Trimble Connected Ecosystem, bringing real world data to the core of more decision making

UN  LOCK

# Reality Capture Breakthrough Innovation

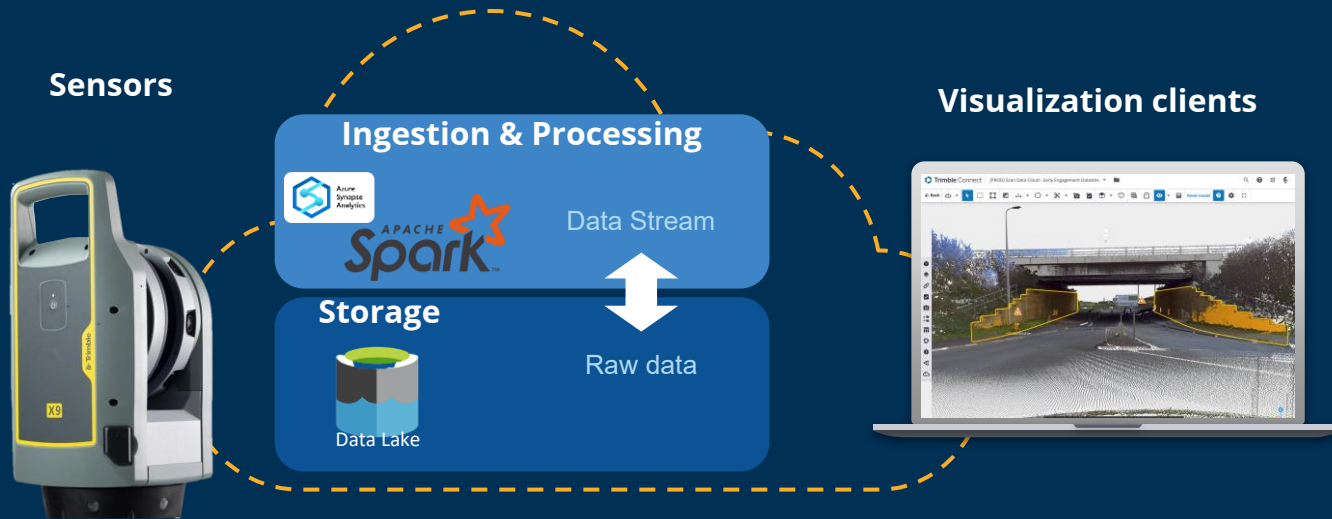

Architected to support **Petabytes** of data, working with point clouds natively - Leveraging our Microsoft partnership



# Reality Capture Key Capabilities

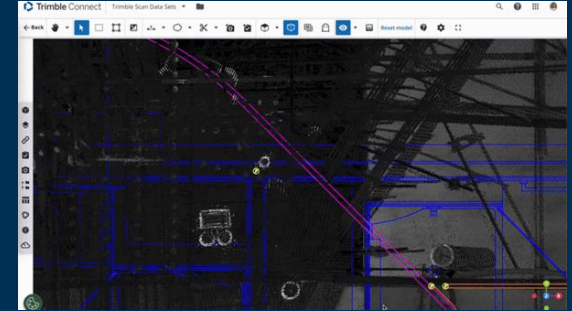
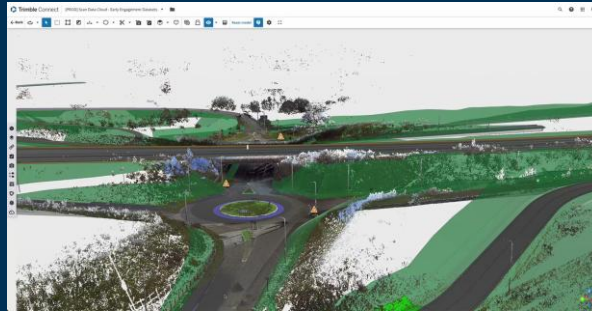
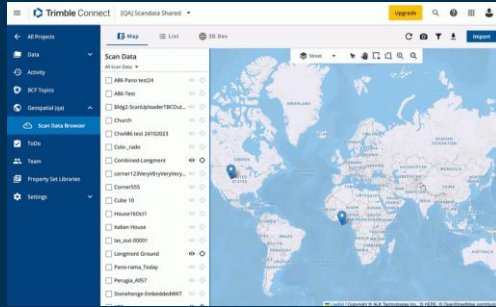

## Intuitive Data Management

- Find data in geographic context
- Data and attributes in list view
- Search and tag

## Seamless BIM Integration

- Powerful BIM visualization
- Point cloud & Station Views
- Measurements & Annotations
- BCF Topics

## Cross Product Collaboration

- Cross product sharing of information through BCF Topics
- Streaming of reality capture data across Trimble Ecosystem



# Trimble Connect

A cloud-based common data environment and open collaboration platform.

Connecting the right people  
to the right data  
at the right time together  
with the right processes.

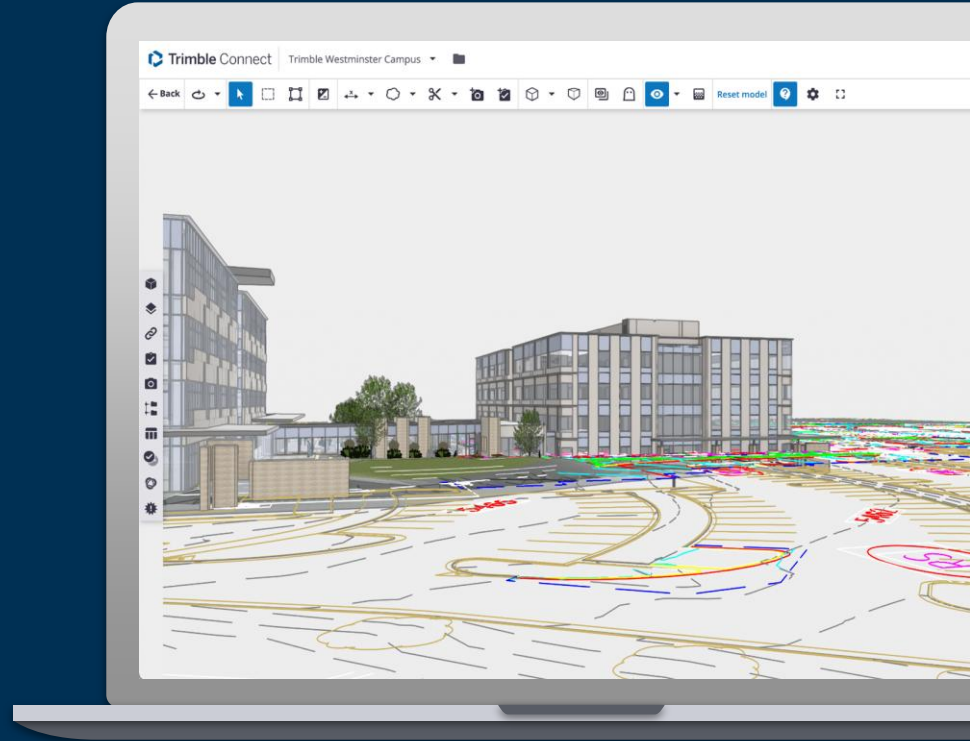



# Connecting the physical and digital world

Trimble Field Systems connects the physical and digital worlds by offering innovative positioning technology and site management solutions, and unified workflows that boost productivity and connect all project phases.

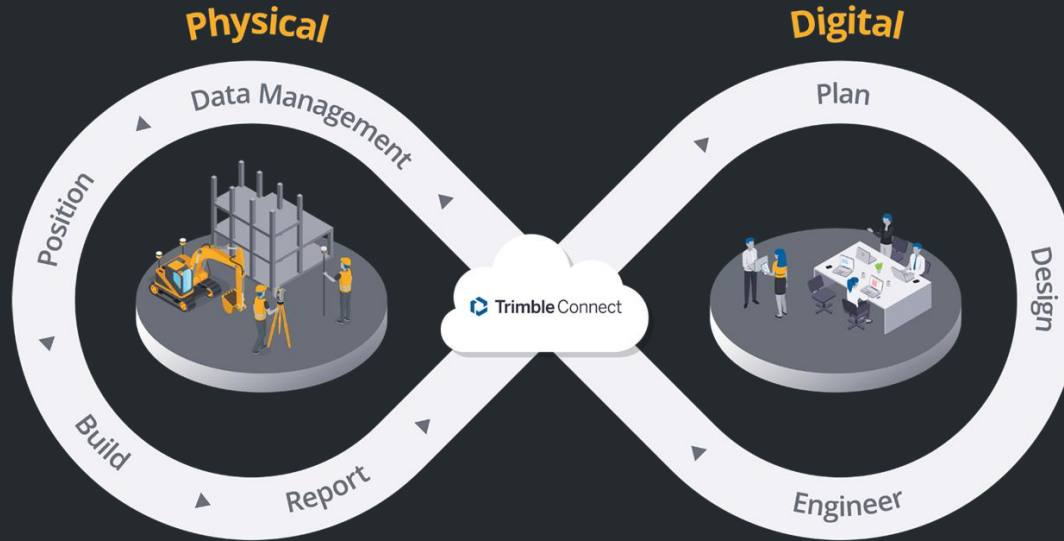

# Point Cloud Classification

- Automatic point cloud filtering on import
- Leveraging TBC AI algorithms
- Modes for indoor and outdoor datasets

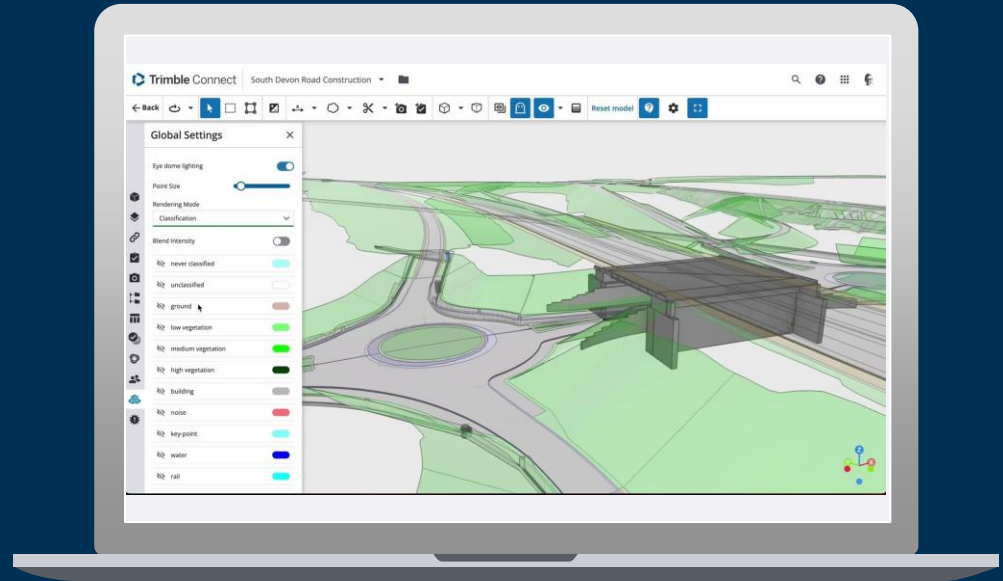

# Scan to BIM

- Dynamic generation of clearance “heatmaps”
- Automatic analysis of multiple objects and multiple point cloud datasets
- User defined visualization
- Shareable through BCF Topics and views

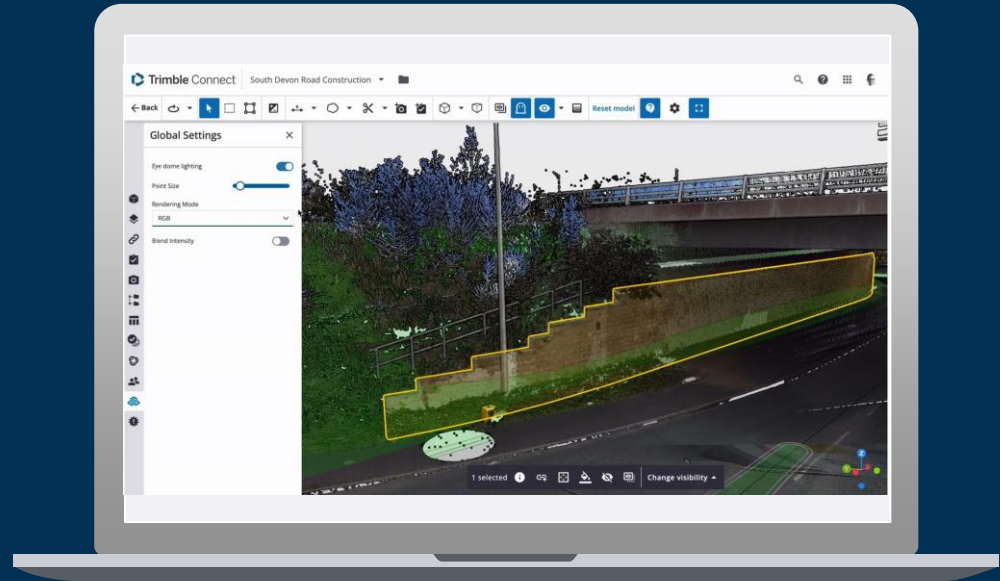

# Scan to BIM

- Dynamic generation of clearance “heatmaps”
- Automatic analysis of multiple objects and multiple point cloud datasets
- User defined visualization
- Shareable through BCF Topics and views

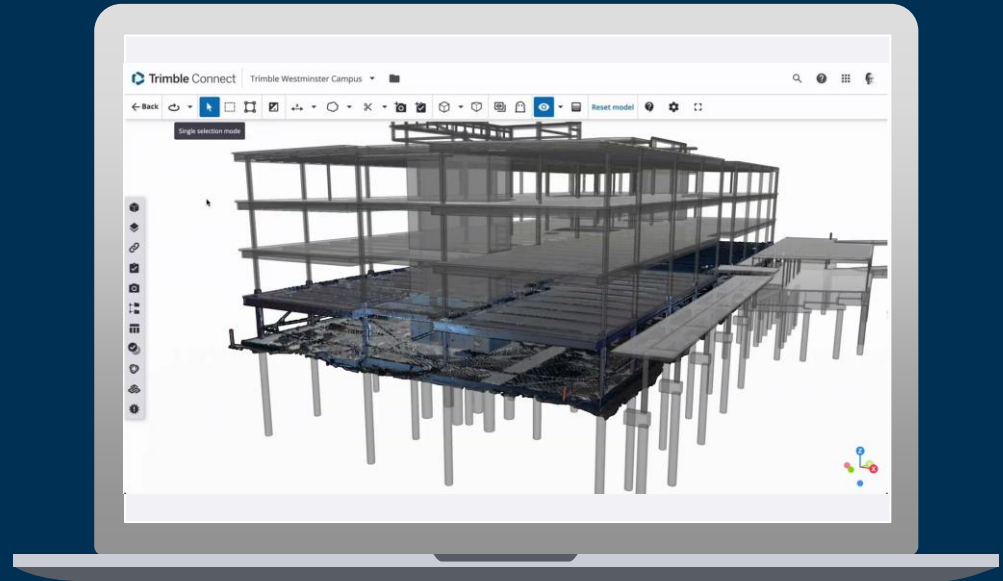

# Vertical Analysis / Floor Flatness

- Dynamic generation of floor flatness maps
- User defined elevation reference
- User defined visualization
- Shareable through BCF Topics and views

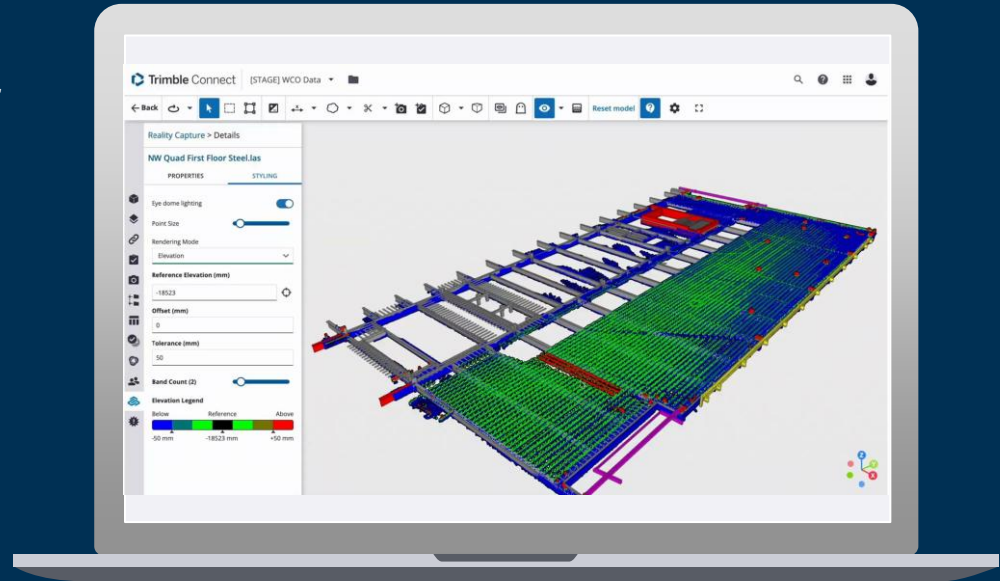

# Clip Box

- Isolate specific areas
- Clip 3D models and point clouds
- Create clip boxes from model objects
- Resize and move clip box

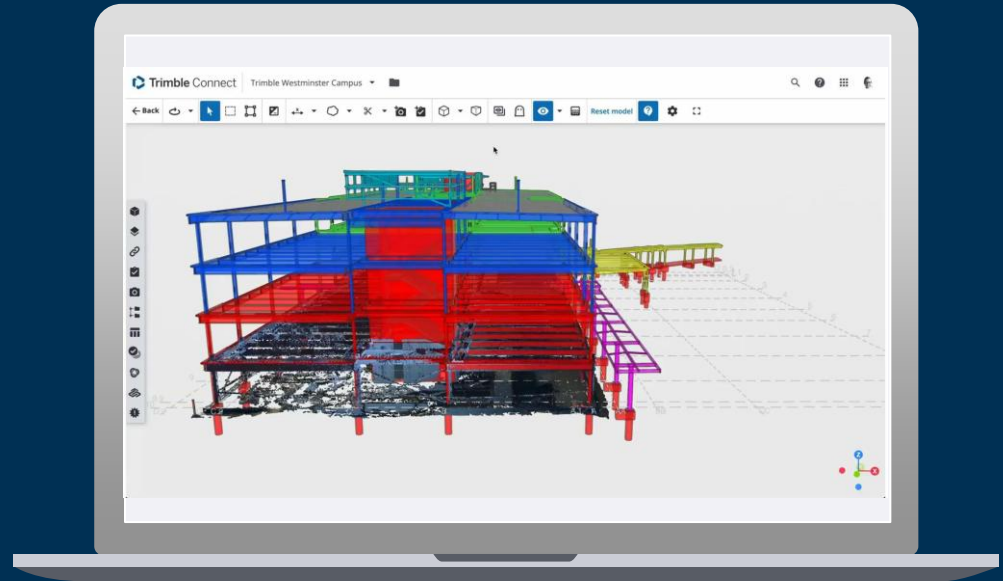

# Tekla Integration

## TRCPS integration

- 2025 Stream Data
- Limit Box
- Inspection

## Layout Manager

- Automatically create points
- As-built updates

## BCF Topic Support

- Collaborate issues and questions
- Field and model coordination

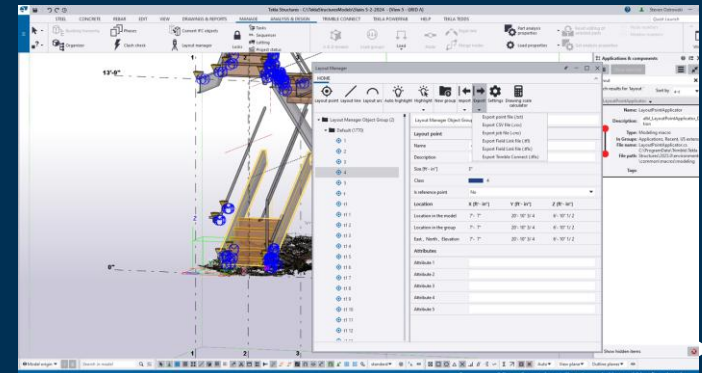
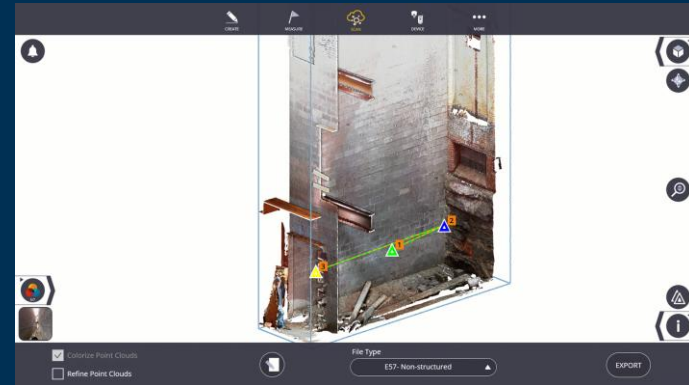

# Trimble X9 Core Lite Scanning workflows Exemple

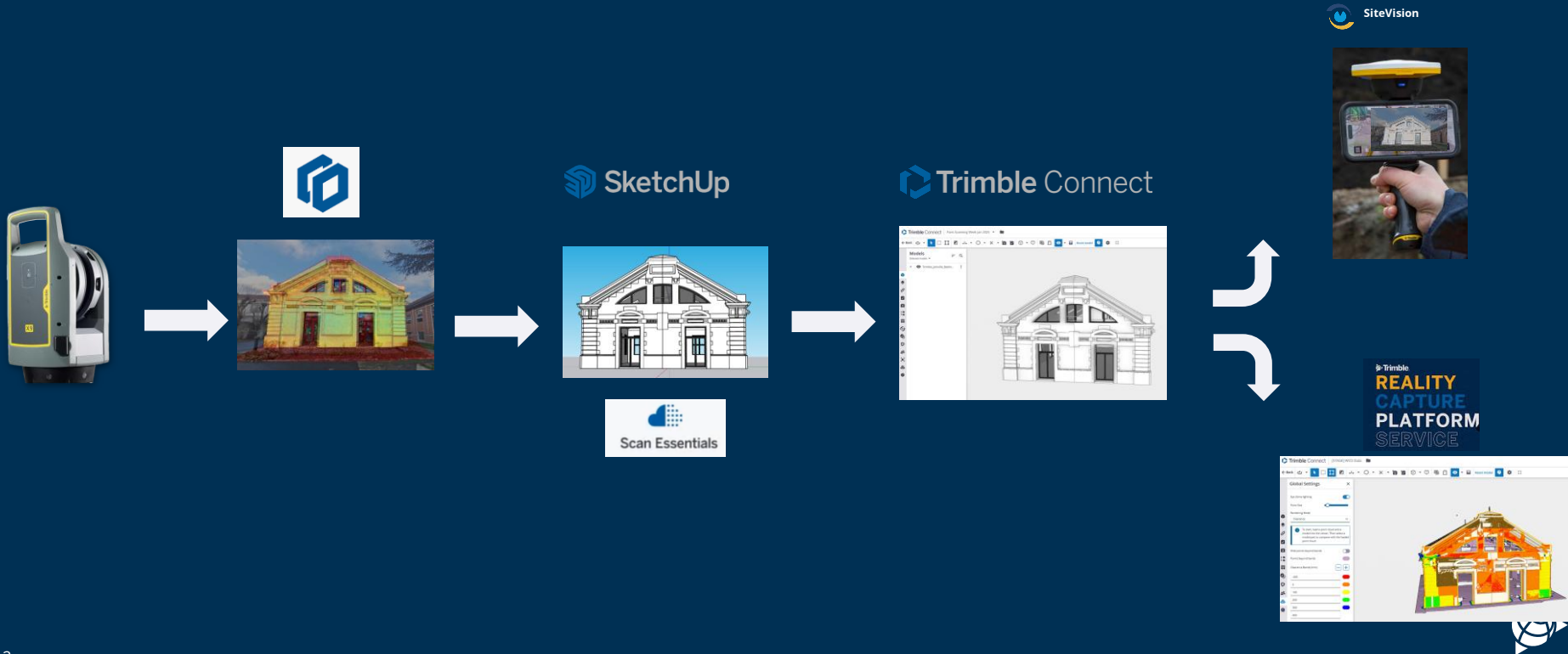

# From Discovery to Digital Twin: Documenting Historical Site with Reality Capture



- During the excavation for a new hotel and office building in Vilnius, Lithuania, construction workers unearthed the foundation of a water treatment station built between 1910 and 1914. To document the discovery, an archaeological research company used a four-step digital preservation workflow.

The process involved:

- Capture detailed point cloud data using an X7
- Use Catalyst and DA2 for easy control point creation to georef in the field the scans (use X7 laser pointer)
- **SketchUp** to create a 3D model from old blueprints and photos.
- **SiteVision** augmented reality system to visualize the original building on-site at a 1:1 scale.

This digital approach successfully met regulatory requirements and allowed construction to proceed without delay while preserving the historical information.

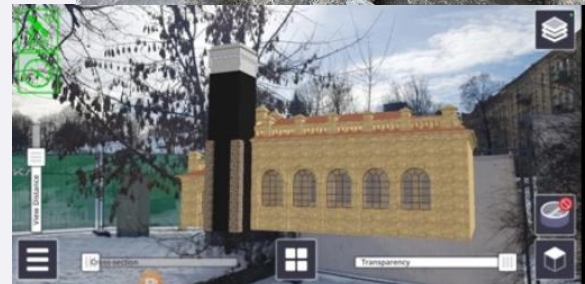

# Concrete workflows



## Workflows

### Concrete Flatwork

- Aggregate analysis
- Wet Concrete
- FF/FL ASTM E1155
- Post Pour Survey

### Verticality

Compliance for ramps-ADA, parking decks, etc

## Tools

- Immediate elevation views
- Surface analysis report
- Layout high/low spots
- Compute

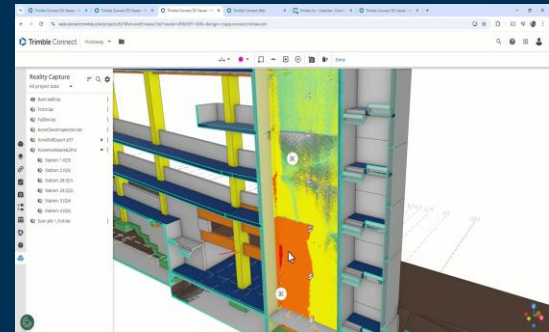
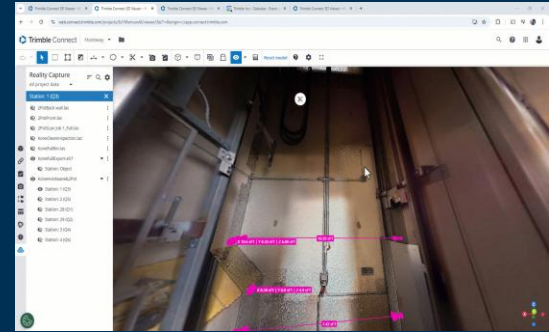

# Sitevision: Real time collaboration between field and office

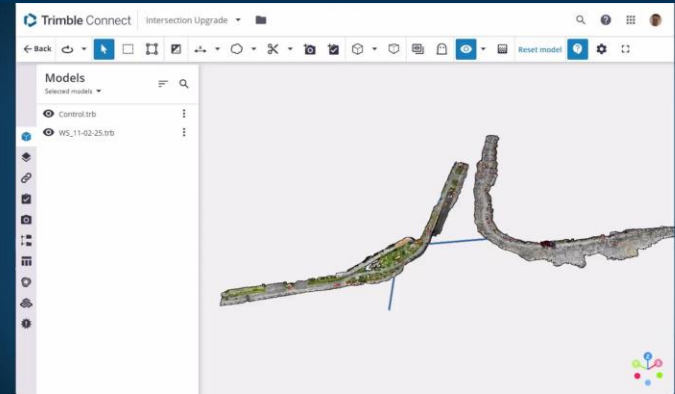



# Scanning Applications

# Top 3D Scanning Applications

- Topographic/General Surveys
- Industrial Surveys
- Civil Infrastructure
- Building Construction/Facility Management
- Forensics
- Utilities
- Architecture
- Mining
- Cultural Heritage
- Tank Calibration & Inspection
- And many more!!!





# Building Construction / Facility Management

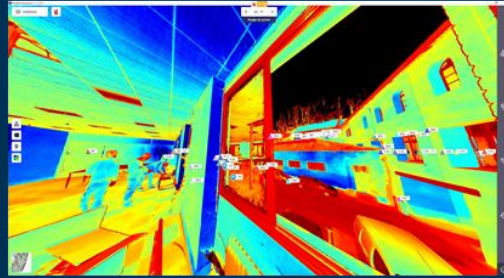

# Construction / Inspections

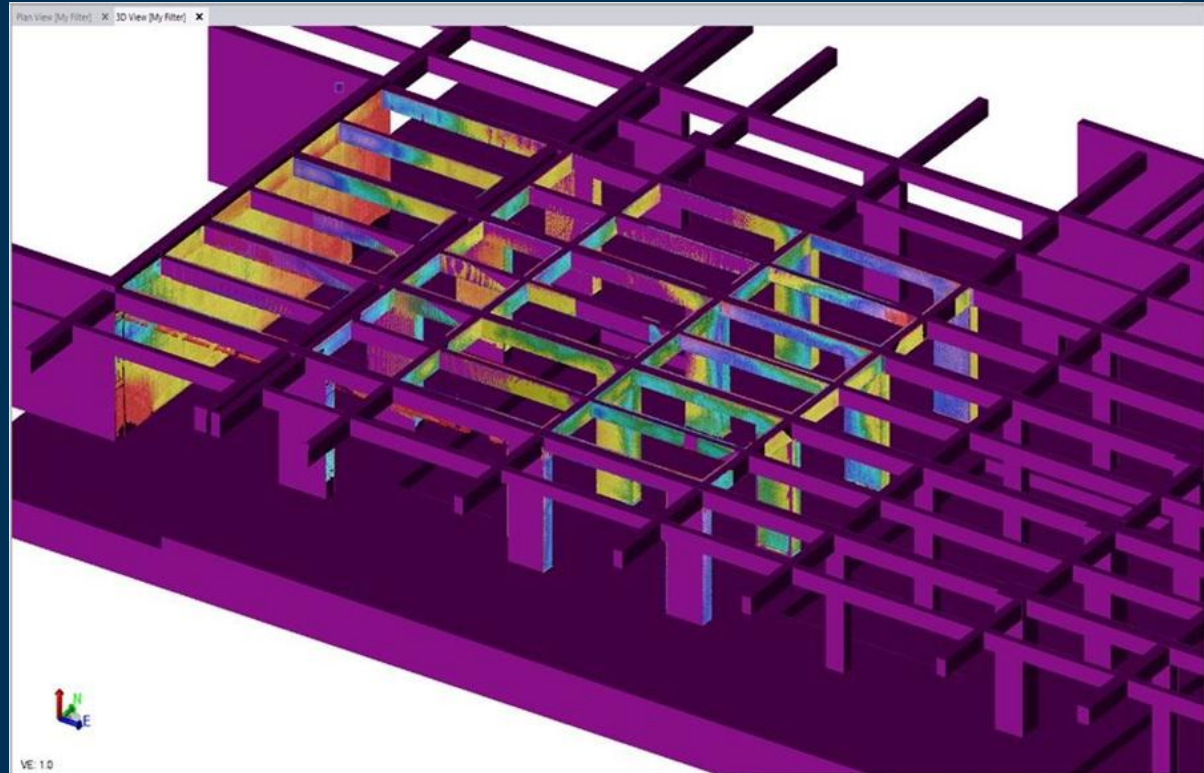

# Industrial Surveys

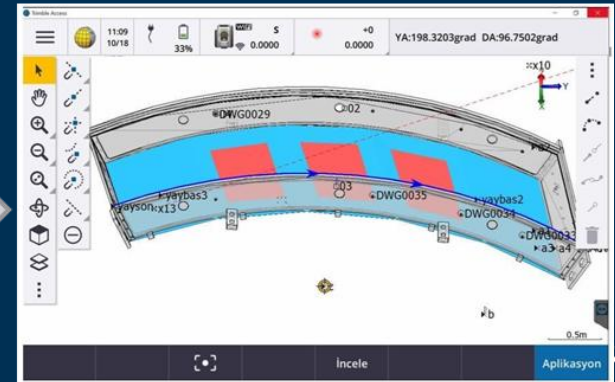

# Industrial Surveys

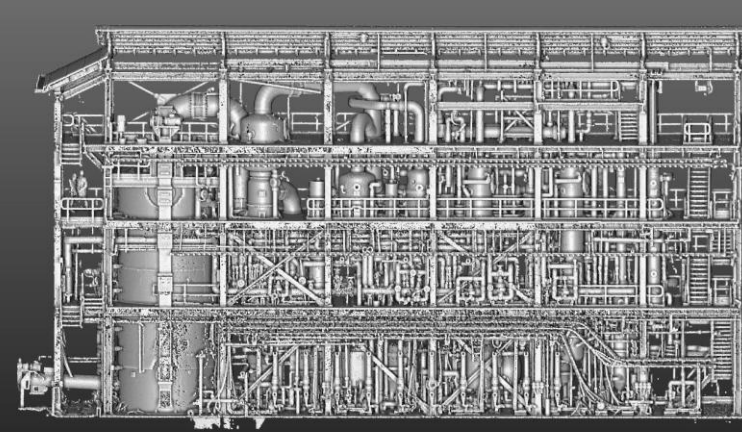
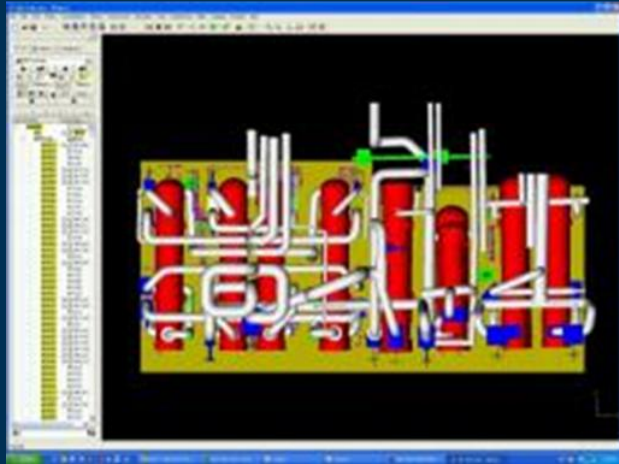

# Tanks

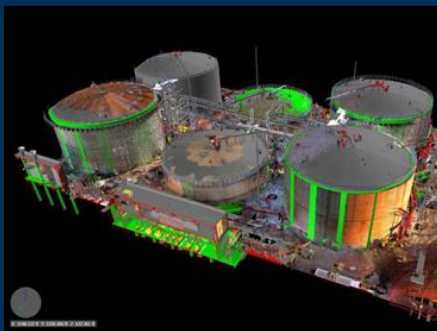
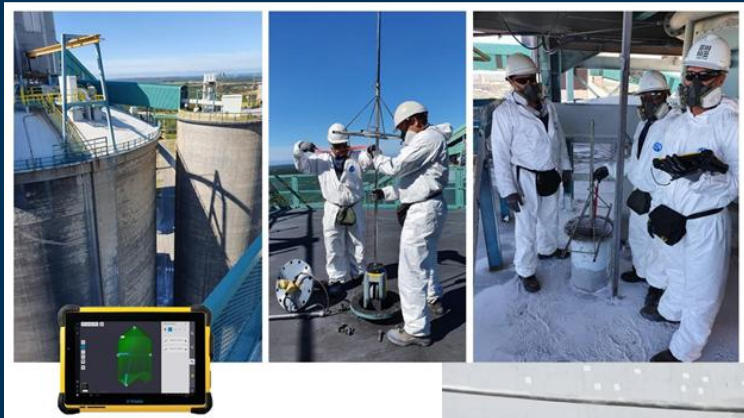

# Tanks

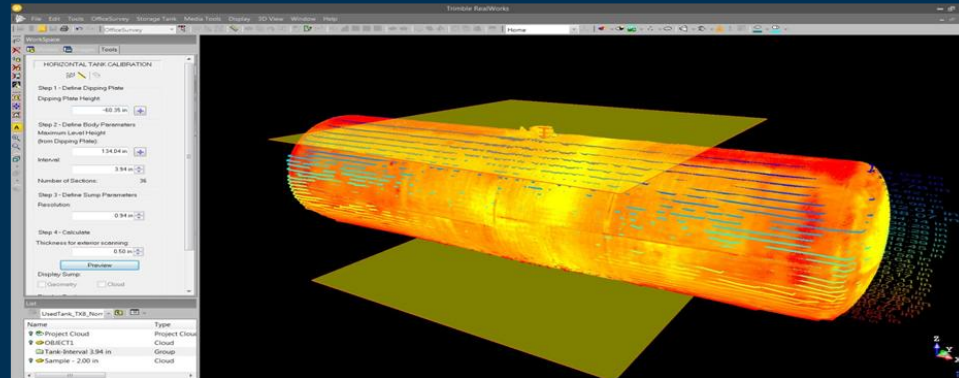
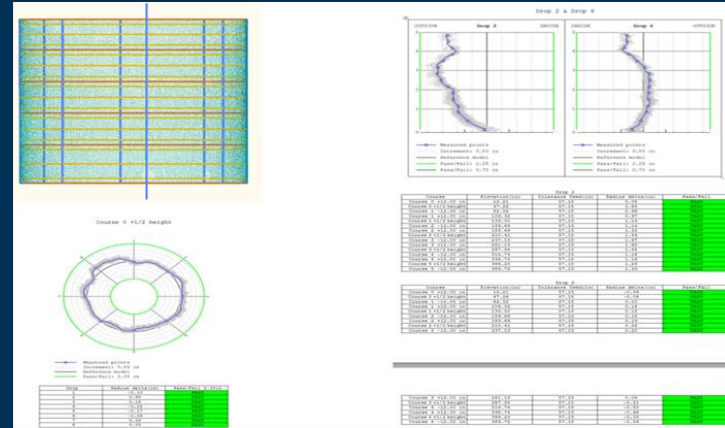
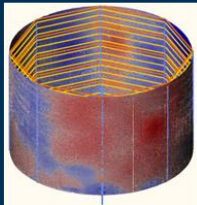
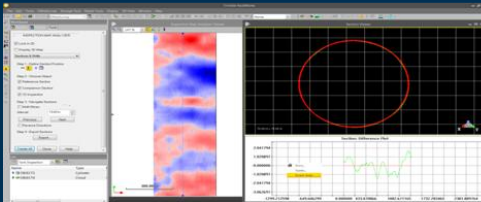
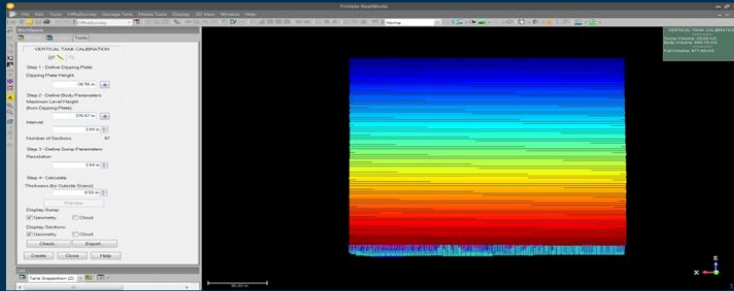

# Civil Infrastructure

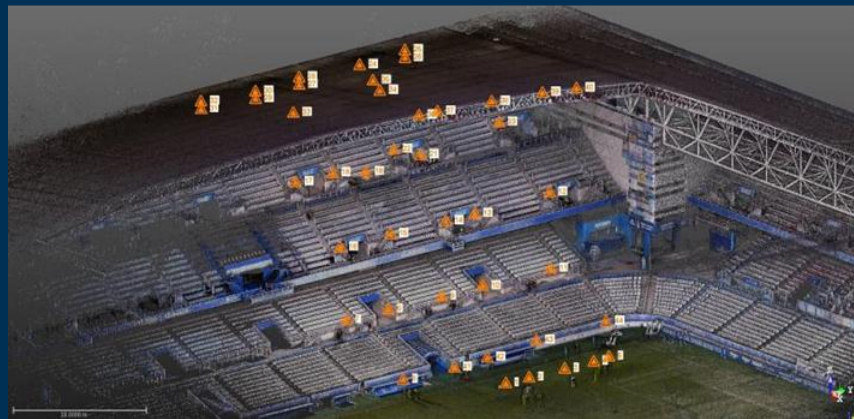
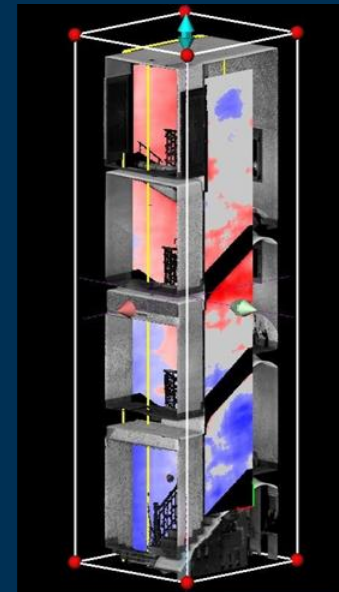

File Home Survey GIS CAD Drafting Surfaces Corridors Point Clouds Construction Data Photogrammetry Tunnels Mobile Mapping Data Prep Takeoff Site Mass Haul Corridor Mass Haul Utility Drill File Compact Macros Support

Register Scans Georeference Scans Create Scan Station  
 Create Region Keep Out Keep In Restore All Restore  
 Classify Sample by Intensity  
 Limit Box 3D View Top Z Axis Up Station View  
 Plane Manager Cutting Plane View  
 True Color Colorize Scans  
 Scan to CAD Extract Point Feature Orthophoto Rectified Image  
 Process Panoramas Publish to Clarity

View Filter Man... Plan View [My Filter] 3D View [My Filter] Station View [My Filter] : 3 (S2)



My Filter  
 <Everything>

Point Cloud Regions

- Default
- Buildings
- Ground
- High vegetation
- Poles and signs
- Power lines

Scans

- 1 (S1) Scan 1
- 1 (S1) Scan 2
- 1 (S1) Scan 3
- 3 (S2) Scan 4
- 4 (S6) Scan 8
- 4 (S6) Scan 9
- 5 (S5) Scan 7
- 6 (S3) Scan 5
- 7 (S4) Scan 6

Raw Data

- Baseline
- PP Continuous
- PP Stop and Go Ve
- PP Vector
- PP Vector Imported
- RTK Vector
- As-Stacked Point
- Azimuth
- Offset
- Point
- Averaged Point Rel
- Laser Rangefinder
- Leveling
- Media Folder
- Total Station

Point Observations GN: <

- Show point IDs
- Show point symbols
- Show feature code
- Show elevation

# Highway, Bridges

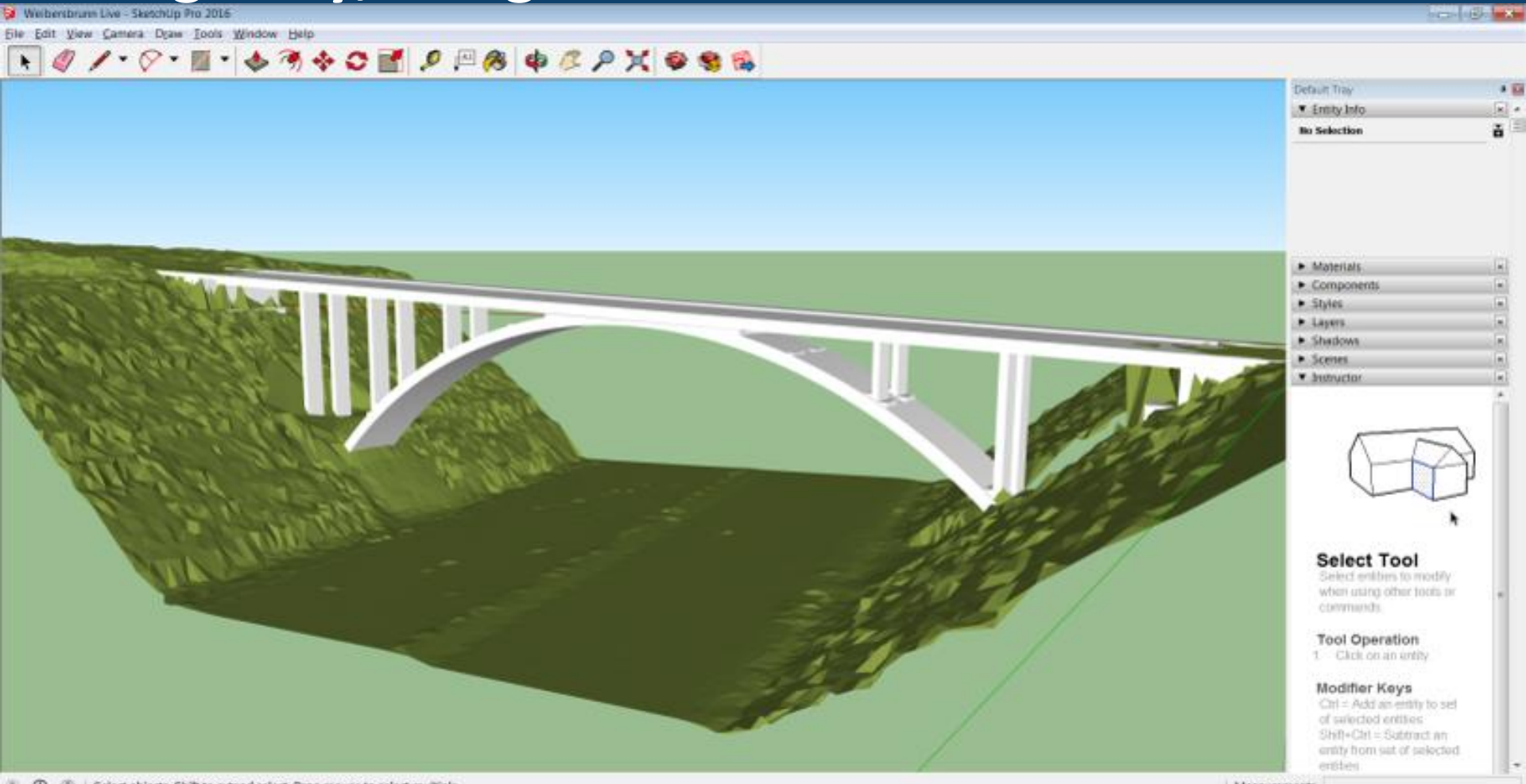

# Bridges Inspection

Bridge of Noirmoutier, France.

Needed to be surveyed (existing control points) and inspected (measurement visual)

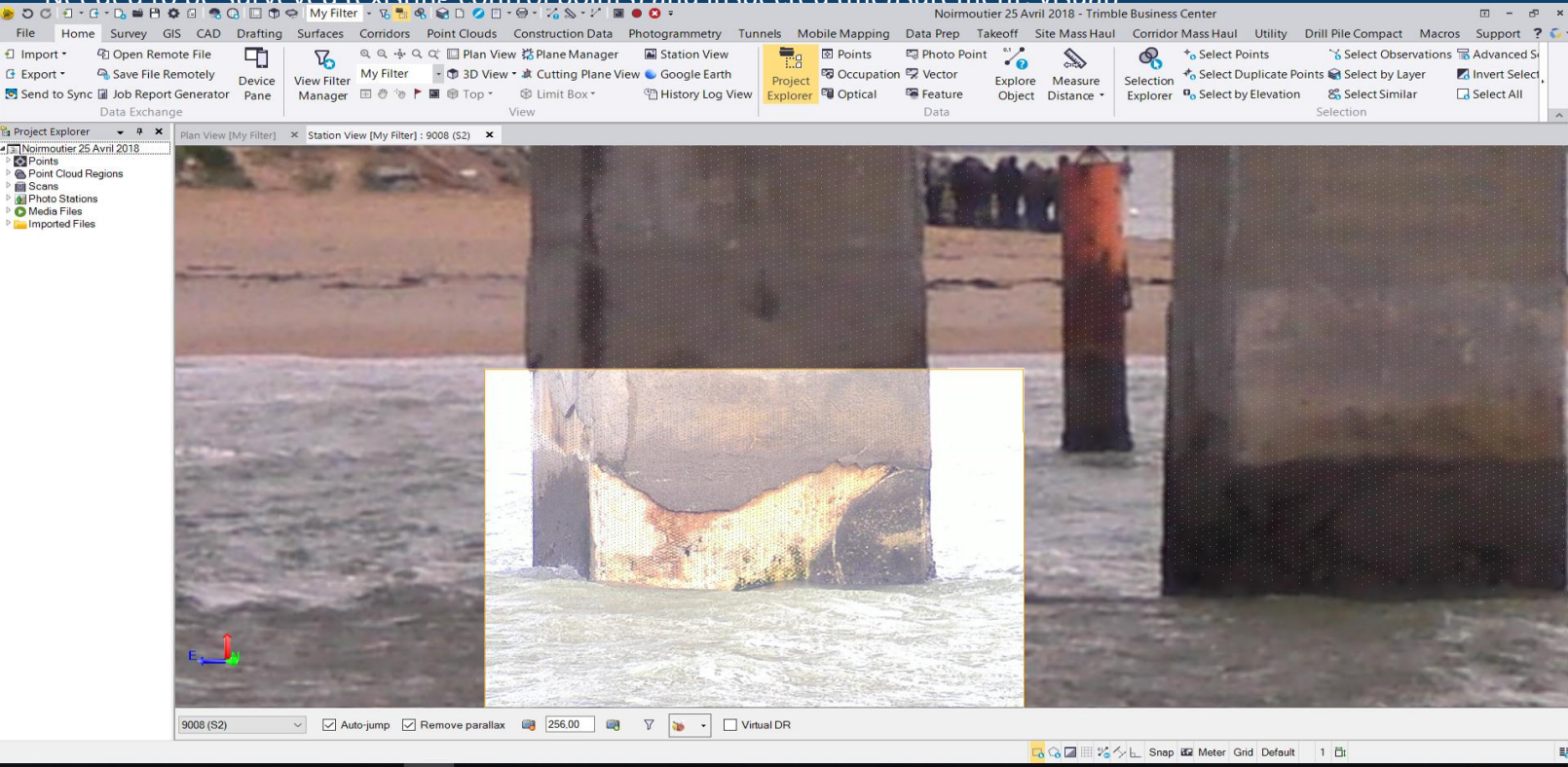

# Naval, Automotive, Aerospace, Rail



# Tunnels, Mines

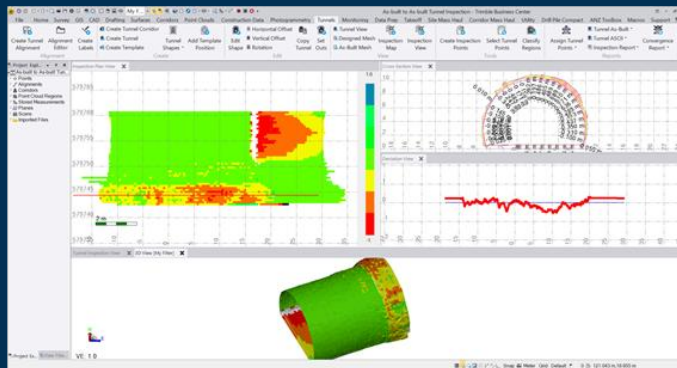
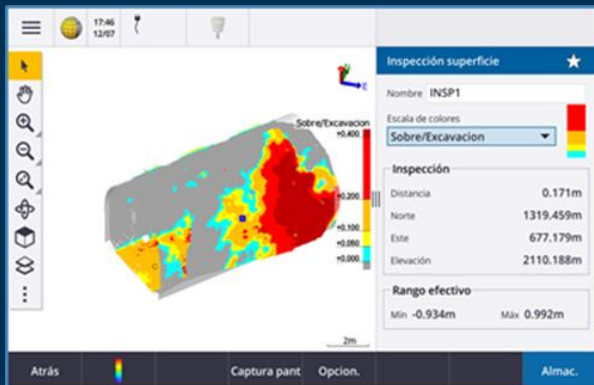
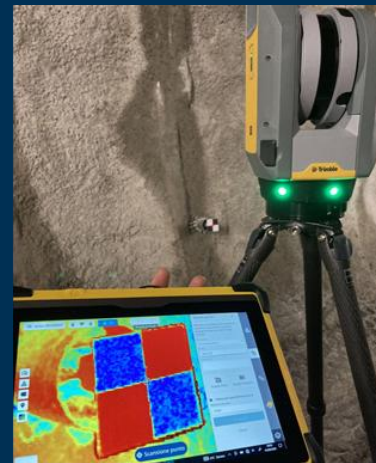

# Volumes, Inspection

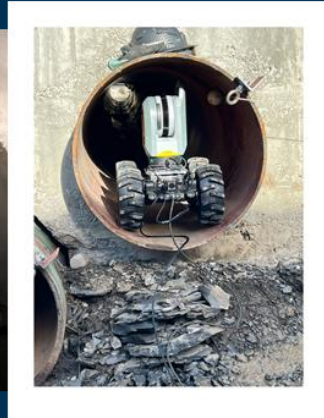
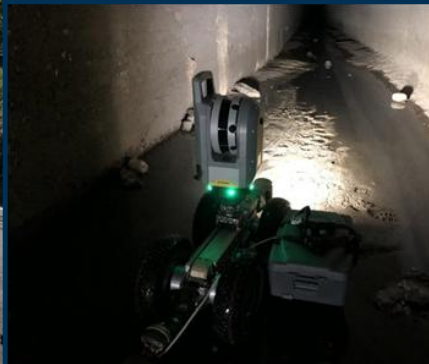
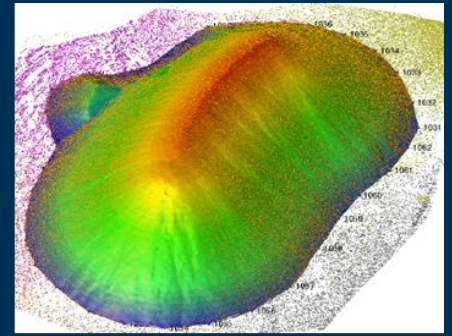

# Cultural Heritage

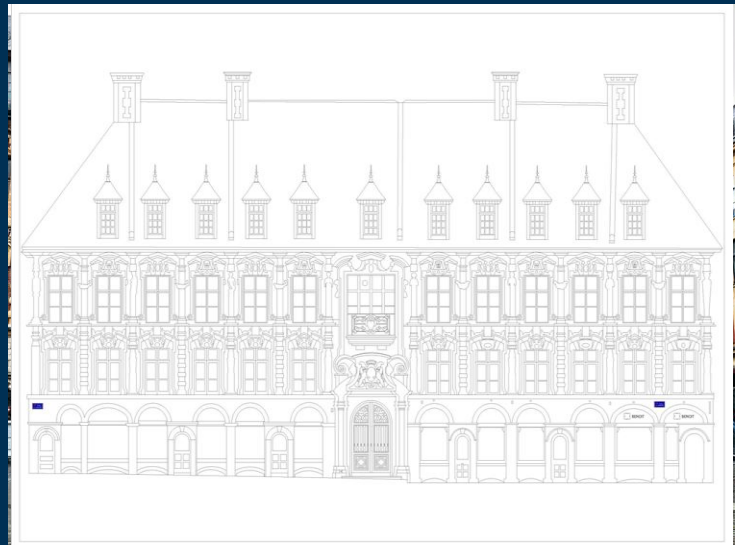
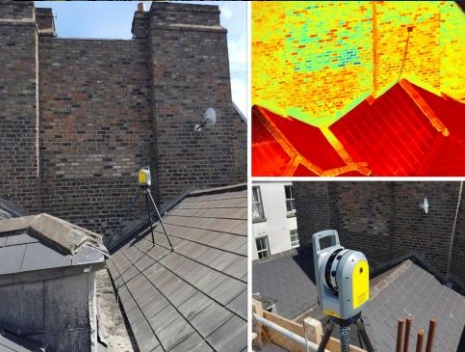

# Forensics

Visit: <https://forensics.trimble.com>

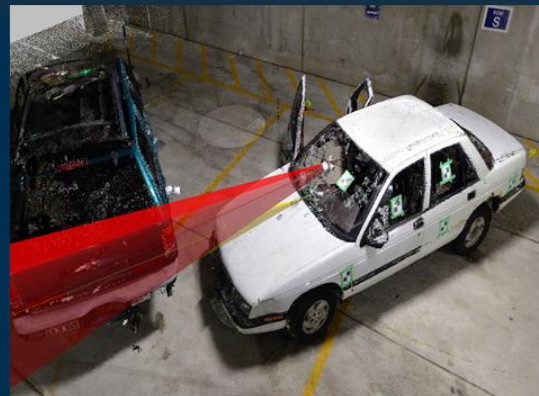
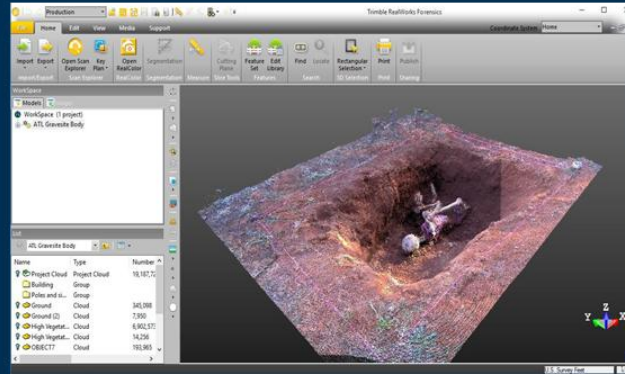

# **3D Scanning Journey Exemple**

---



# General Surveying and Floor plan modeling



File Home Sur

Layer Manager

- Layer Group
- Relayer Obj
- Standardiz
- Layers

View Filter Manager

Mon filtre

<Everything>

Point Cloud Reg

- Défaut
- Immeuble
- Poteaux et sig
- Terrain
- topo
- Végétation ha

Scans

- 1 36 (Y36)
- 2 35 (Y35)
- 3 71 (Y71)
- 4 59 (Y59)
- 5 96 (Y96)
- 6 72 (Y72)
- 7 48 (Y48)
- 8 11 (Y11)
- 9 23 (Y23)
- 10 84 (Y84)
- 11 47 (Y47)
- 12 12 (Y12)
- 13 24 (Y24)
- 14 60 (Y60)

Point Observations GNS

- Show point IDs
- Show point symbols
- Show feature code
- Show elevation
- Show disconnected poin

Project Explorer View

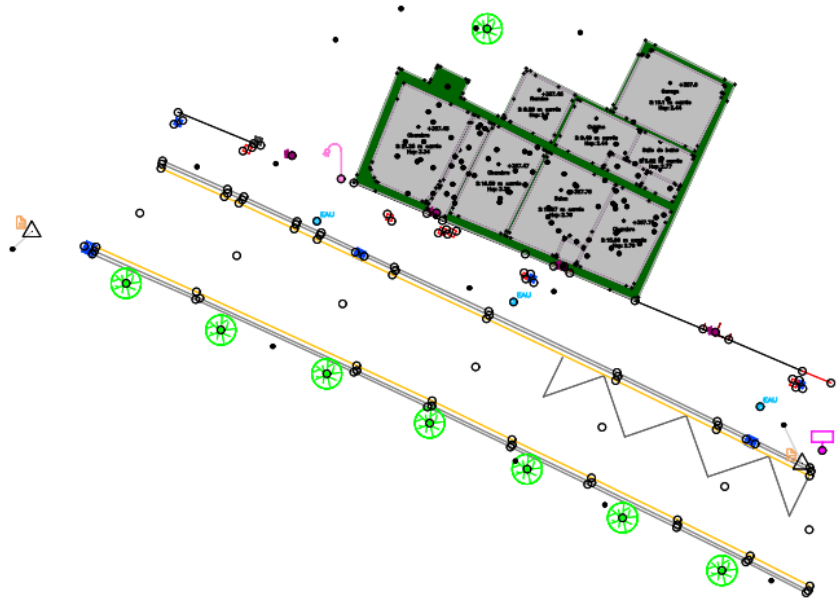

Welcome to Portugal

NO.

SHEET  
1 OF 1

Georef Image Images

