



USER GUIDE

# TDL450B

RADIO

---

Revision B  
May 2024

# Legal Notices

10368 Westmoor Drive  
Westminster, CO 80021  
USA

[trimble.com](http://trimble.com)

## Legal Notices

© 2024, Trimble Inc. All rights reserved.

Trimble, the Globe & Triangle logo, and Trimble RTX are trademarks of Trimble Inc., registered in the United States and in other countries. TRIMTALK is a trademark of Trimble Inc.

The Bluetooth word mark and logos are owned by the Bluetooth SIG, Inc. and any use of such marks by Trimble Inc. is under license.

## Release Notice

This is the May 2024 release (Revision B) of the TDL450B documentation.

## Product Warranty Information

### LIMITED WARRANTY TERMS AND CONDITIONS

#### Product Limited Warranty

Subject to the following terms and conditions, Trimble Inc. ("Trimble") warrants that for a period of one (1) year from date of purchase unless otherwise specified, this Trimble product (the "Product") will substantially conform to Trimble's publicly available specifications for the Product and that the hardware and any storage media components of the Product will be substantially free from defects in materials and workmanship.

#### Product Software

Product software, whether built into hardware circuitry as firmware, provided as a standalone computer software product, embedded in flash memory, or stored on magnetic or other media, is licensed solely for use with or as an integral part of the Product and is not sold. If accompanied by a separate end user license agreement ("EULA"), use of any such software will be subject to the terms of such end user license agreement (including any differing limited warranty terms, exclusions, and limitations), which shall control over the terms and conditions set forth in this limited warranty.

#### Software Fixes

During the limited warranty period you will be entitled to receive such Fixes to the Product software that Trimble releases and makes commercially available and for which it does not charge separately, subject to the procedures for delivery to purchasers of Trimble products generally. If you have purchased the Product from an authorized Trimble dealer rather than from Trimble directly, Trimble may, at its option, forward the software Fix to the Trimble dealer for final distribution to you. Minor Updates, Major Upgrades, new products, or substantially new software releases, as identified by Trimble, are expressly excluded from this update process and limited warranty. Receipt of software Fixes or other enhancements shall not serve to extend the limited warranty period.

For purposes of this warranty the following definitions shall apply: (1) "Fix(es)" means an error correction or other update created to fix a previous software version that does not substantially conform to its Trimble specifications; (2) "Minor Update" occurs when enhancements are made to current features in a software program; and (3) "Major Upgrade" occurs when significant new features are added to software, or when a new product containing new features replaces the further development of a current product line. Trimble reserves the right to determine, in its sole discretion, what constitutes a Fix, Minor Update, or Major Upgrade.

#### Warranty Remedies

If the Trimble Product fails during the warranty period for reasons covered by this limited warranty and you notify Trimble of such failure during the warranty period, Trimble will repair OR replace the nonconforming Product with new, equivalent to new, or reconditioned parts or Product, OR refund the Product purchase price paid by you, at Trimble's option, upon your return of the Product in accordance with Trimble's product return procedures then in effect.

## How to Obtain Warranty Service

To obtain warranty service for the Product, please contact your local Trimble authorized dealer. Alternatively, you may contact Trimble to request warranty service by e-mailing your request to [repair\\_services@trimble.com](mailto:repair_services@trimble.com). Please be prepared to provide:

- your name, address, and telephone numbers
- proof of purchase
- a copy of this Trimble warranty
- a description of the nonconforming Product including the model number
- an explanation of the problem

The customer service representative may need additional information from you depending on the nature of the problem.

## Warranty Exclusions or Disclaimer

This Product limited warranty shall only apply in the event and to the extent that (a) the Product is properly and correctly installed, configured, interfaced, maintained, stored, and operated in accordance with Trimble's applicable operator's manual and specifications, and; (b) the Product is not modified or misused. This Product limited warranty shall not apply to, and Trimble shall not be responsible for, defects or performance problems resulting from (i) the combination or utilization of the Product with hardware or software products, information, data, systems, interfaces, or devices not made, supplied, or specified by Trimble; (ii) the operation of the Product under any specification other than, or in addition to, Trimble's standard specifications for its products; (iii) the unauthorized installation, modification, or use of the Product; (iv) damage caused by: accident, lightning or other electrical discharge, fresh or salt water immersion or spray (outside of Product specifications); or exposure to environmental conditions for which the Product is not intended; (v) normal wear and tear on consumable parts (e.g., batteries); or (vi) cosmetic damage. Trimble does not warrant or guarantee the results obtained through the use of the Product, or that software components will operate error free.

**NOTICE REGARDING PRODUCTS EQUIPPED WITH TECHNOLOGY CAPABLE OF TRACKING SATELLITE SIGNALS FROM SATELLITE BASED AUGMENTATION SYSTEMS (SBAS) (WAAS/EGNOS, AND MSAS), OMNISTAR, GPS, MODERNIZED GPS OR GLONASS SATELLITES, OR FROM IALA BEACON SOURCES: TRIMBLE IS NOT RESPONSIBLE FOR THE OPERATION OR FAILURE OF OPERATION OF ANY SATELLITE BASED POSITIONING SYSTEM OR THE AVAILABILITY OF ANY SATELLITE BASED POSITIONING SIGNALS.**

THE FOREGOING LIMITED WARRANTY TERMS STATE TRIMBLE'S ENTIRE LIABILITY, AND YOUR EXCLUSIVE REMEDIES, RELATING TO THE TRIMBLE PRODUCT. EXCEPT AS OTHERWISE EXPRESSLY PROVIDED HEREIN, THE PRODUCT, AND ACCOMPANYING DOCUMENTATION AND MATERIALS ARE PROVIDED "AS-IS" AND WITHOUT EXPRESS OR IMPLIED WARRANTY OF ANY KIND, BY EITHER TRIMBLE OR ANYONE WHO HAS BEEN INVOLVED IN ITS CREATION, PRODUCTION, INSTALLATION, OR DISTRIBUTION, INCLUDING, BUT NOT LIMITED TO, THE IMPLIED WARRANTIES OF MERCHANTABILITY AND FITNESS FOR A PARTICULAR PURPOSE, TITLE, AND NONINFRINGEMENT. THE STATED EXPRESS WARRANTIES ARE IN LIEU OF ALL OBLIGATIONS OR LIABILITIES ON THE PART OF TRIMBLE ARISING OUT OF, OR IN CONNECTION WITH, ANY PRODUCT. BECAUSE SOME STATES AND JURISDICTIONS DO NOT ALLOW LIMITATIONS ON DURATION OR THE EXCLUSION OF AN IMPLIED WARRANTY, THE ABOVE LIMITATION MAY NOT APPLY OR FULLY APPLY TO YOU.

## Limitation of Liability

TRIMBLE'S ENTIRE LIABILITY UNDER ANY PROVISION HEREIN SHALL BE LIMITED TO THE AMOUNT PAID BY YOU FOR THE PRODUCT. TO THE MAXIMUM EXTENT PERMITTED BY APPLICABLE LAW, IN NO EVENT SHALL TRIMBLE OR ITS SUPPLIERS BE LIABLE FOR ANY INDIRECT, SPECIAL, INCIDENTAL, OR CONSEQUENTIAL DAMAGE WHATSOEVER UNDER ANY CIRCUMSTANCE OR LEGAL THEORY RELATING IN ANYWAY TO THE PRODUCTS, SOFTWARE AND ACCOMPANYING DOCUMENTATION AND MATERIALS, (INCLUDING, WITHOUT LIMITATION, DAMAGES FOR LOSS OF BUSINESS PROFITS, BUSINESS INTERRUPTION, LOSS OF DATA, OR ANY OTHER PECUNIARY LOSS), REGARDLESS OF WHETHER TRIMBLE HAS BEEN ADVISED OF THE POSSIBILITY OF ANY SUCH LOSS AND REGARDLESS OF THE COURSE OF DEALING WHICH DEVELOPS OR HAS DEVELOPED BETWEEN YOU AND TRIMBLE. BECAUSE SOME STATES AND JURISDICTIONS DO NOT ALLOW THE EXCLUSION OR LIMITATION OF LIABILITY FOR CONSEQUENTIAL OR INCIDENTAL DAMAGES, THE ABOVE LIMITATION MAY NOT APPLY OR FULLY APPLY TO YOU.

**PLEASE NOTE: THE ABOVE TRIMBLE LIMITED WARRANTY PROVISIONS WILL NOT APPLY TO PRODUCTS PURCHASED IN THOSE JURISDICTIONS (E.G., MEMBER STATES OF THE EUROPEAN ECONOMIC AREA) IN WHICH PRODUCT WARRANTIES ARE THE RESPONSIBILITY OF THE LOCAL TRIMBLE AUTHORIZED DEALER FROM WHOM THE PRODUCTS ARE ACQUIRED. IN SUCH A CASE, PLEASE CONTACT YOUR LOCAL TRIMBLE AUTHORIZED DEALER FOR APPLICABLE WARRANTY INFORMATION.**

## Official Language

THE OFFICIAL LANGUAGE OF THESE TERMS AND CONDITIONS IS ENGLISH. IN THE EVENT OF A CONFLICT BETWEEN ENGLISH AND OTHER LANGUAGE VERSIONS, THE ENGLISH LANGUAGE SHALL CONTROL.

# Safety and Regulatory Information

Before you use your Trimble product, make sure that you have read and understood all safety requirements.

**WARNING** – This alert warns of a potential hazard which, if not avoided, could result in severe injury or even death.

**CAUTION** – This alert warns of a potential hazard or unsafe practice that could result in minor injury or property damage or irretrievable data loss.

**NOTE** – An absence of specific alerts does not mean that there are no safety risks involved.

## Use and care

This product is designed to withstand the rough treatment and tough environment that typically occurs in construction applications. However, the TDL450B radio is a high-precision electronic instrument and should be treated with reasonable care.

Operating or storing the radio outside the specified temperature range can damage it. Storage temperature range -40 °C to +85 °C (-40 °F to 185 °F) in a dry environment.

## Regulations and safety

The TDL450B radio requires a license for use. For licensing information, consult your local Trimble dealer.

It is the responsibility of the end user to obtain an operator's permit or license for the location or country of use.

## Regulatory compliance

The TDL450B radio complies with the following regulations:

- EN 300 113 (RF-requirements)
- EN 301 489 (EMC-requirements)
- EN 62368-1 (Safety Standard)
- FCC CFR47 Part 90 (Private Land Mobile Radio Service)
- Regulatory model number: 129681

The TDL450B radio is allowed to be used in the following countries, either on license-free channels or on channels where the operation requires a license. More detailed information is available at the local frequency management authority:

Countries: AT, AU, BE, BG, CA, CH, CY, CZ, DE, DK, EE, ES, FI, FR, GB, GR, HU, IE, IS, IT, LT, LU, LV, MT, NL, NO, PL, PT, RO, RU, SE, SK, UK (NI), and US.

#### WARNING

Users of radio modems in North America should be aware, that due to the allocation of the frequency band 406.0 - 406.1 MHz for government use only, the use of radio modem on this frequency band without a proper permit is strictly forbidden.

In USA and Canada this product is certified to use frequencies 406.1 - 430 MHz and 450 - 470 MHz. Using this device in USA or Canada outside these frequencies is prohibited.

This device complies with part 15 of the FCC rules. Operation is subject to the following two conditions:

(1) This device may not cause harmful interference, and (2) this device must accept any interference received, including interference that may cause undesired operation.

**NOTE** - This equipment has been tested and found to comply with the limits for a Class B digital device, pursuant to part 15 of the FCC Rules. These limits are designed to provide reasonable protection against harmful interference in a residential installation. This equipment generates, uses and can radiate radio frequency energy and, if not installed and used in accordance with the instructions, may cause harmful interference to radio communications. However, there is no guarantee that interference will not occur in a particular installation. If this equipment does cause harmful interference to radio or television reception, which can be determined by turning the equipment off and on, the user is encouraged to try to correct the interference by one or more of the following measures:

- Reorient or relocate the receiving antenna.
- Increase the separation between the equipment and receiver.
- Connect the equipment into an outlet on a circuit different from that to which the receiver is connected. Consult the dealer or an experienced radio / TV technician for help.

## Compliance information - USA



The Federal Communications Commission (FCC, USA) has dictated that on 1 January 2013, all radio users transmitting data between s/b 421 and 512 MHz within the United States of America, must operate within 12.5 kHz channels or transmit using the bits per second (bps) settings of 19200 bps when using a 25 kHz channel. For more information on the FCC mandate, please go to [www.fcc.gov/narrowbanding-overview](http://www.fcc.gov/narrowbanding-overview).

## FCC compliance statement

**Regulatory model number:** 129681

FCC Class B - Notice to Users. This device complies with part 15 of the FCC rules.

**RESPONSIBLE PARTY:**

Trimble Inc.

4450 Gibson Drive

Tipp City, Ohio 45371

USA

[trimble.com/en/our-company/about/contact-information](https://trimble.com/en/our-company/about/contact-information)

This device complies with part 15 of the FCC rules. Operation is subject to the following two conditions:

(1) This device may not cause harmful interference, and (2) this device must accept any interference received, including interference that may cause undesired operation.

Changes or modifications made to this equipment not expressly approved by Trimble may void the FCC authorization to operate this equipment.

## Compliance information – Canada

Under Industry Canada regulations, this radio transmitter may only operate using an antenna of a type and maximum (or lesser) gain approved for the transmitter by Industry Canada. To reduce potential radio interference to other users, the antenna type and its gain should be chosen so that the equivalent isotropically radiated power (EIRP) is not more than that required for successful communication.

Conformément à la réglementation d'Industrie Canada, le présent émetteur radio peut fonctionner avec une antenne d'un type et d'un gain maximal (ou inférieur) approuvé pour l'émetteur par Industrie Canada. Dans le but de réduire les risques de brouillage radioélectrique à l'intention des autres utilisateurs, il faut choisir le type d'antenne et son gain de sorte que la puissance isotrope rayonnée équivalente (PIRE) ne dépasse pas l'intensité nécessaire à l'établissement d'une communication satisfaisante.

This Class B digital apparatus complies with Canadian ICES-003.

Cet appareil numérique de la classe B est conforme à la norme NMB-003 du Canada.

This apparatus complies with Canadian RSS-GEN, RS-102.

Cet appareil est conforme à la norme CNR-GEN, CNR-102 du Canada.

## Type approval

Type approval, or acceptance, covers technical parameters of the equipment related to emissions that can cause interference. Type approval is granted to the manufacturer of the transmission equipment, independent from the operation or licensing of the units. Some countries have unique technical requirements for operation in particular radio-modem frequency bands. To comply with those requirements, Trimble may have modified your equipment to be granted type approval.

Unauthorized modification of the units voids the type approval, the warranty, and the operational license of the equipment.

# Exposure to radio frequency radiation

The radio is designed to comply with the following national and international standards and guidelines regarding exposure of human beings to radio frequency electromagnetic energy, in addition to protection against harmful interference of neighboring electrical equipment.

- FCC Report and Order FCC 96-326 (August, 1996)
- American National Standards Institute (C95.3-1992)
- National Council on Radiation Protection and Measurement (NCRP – 1986)
- International Commission on Non-ionizing Radiation Protection (ICNRP-1986)
- European Committee for Electrotechnical Standardization (CENELEC)
- FCC CFR47 Part 15
- FCC CFR47 Part 90 (Private Land Mobile Radio Service)
- Industry Canada RSS119
- ETSI EN 300 133-2
- ETSI EN 300 489
- ACA AS/NZS 4295
- IDA Spec 111
- OFTA STD-1E
- RRC CMII

Contact your Trimble dealer for your country's approval.

## For 450 MHz radio

**Safety.** Exposure to RF energy is an important safety consideration. The FCC has adopted a safety standard for human exposure to radio frequency electromagnetic energy emitted by FCC regulated equipment as a result of its actions in *General Docket 79-144* on March 13, 1986 and *KDB447498, RF Exposure Procedures and Equipment Authorization Policies For Mobile and Portable Devices*.

Proper use of this radio results in exposure below government limits. The following precautions are recommended:

- **DO NOT** operate the transmitter unless all RF connectors are secure and any open connectors are properly terminated.
- **DO NOT** operate the equipment near electrical blasting caps or in an explosive atmosphere.
- All equipment must be properly grounded according to Trimble installation instructions for safe operation.

**CAUTION** – For your own safety, and in terms of the RF exposure requirements of the FCC, always observe these precautions:

- For the 450 MHz radio, always maintain a minimum separation distance of 45 cm (17.7 inches) between yourself and the radiating antenna.
- The 450 MHz radio is using 4FSK and GMSK modulations.
- All equipment should be serviced only by a qualified technician.

## Installing antennas

**WARNING** – RF Exposure! To comply with RF exposure compliance requirements in Europe, USA, and Canada, the maximum antenna gain is 14 dBi and a separation distance listed below must be maintained between the antenna of this device and all persons. This device must not be co-located or operate in conjunction with any other antenna or transmitter.

Antenna gain [dBi]	Minimum distance [m]
0	1.4
4	2.2
6	2.7
8	3.4
10	4.2
12	5.3
14	6.7

**WARNING** – To ensure optimal radio performance and that exposure to RF energy is within the guidelines on the above standards, observe the following operating procedures:

- Do not operate the transceiver unless all RF connectors are secure and any open connectors are properly terminated.
- Avoid contact with the antenna while operating the transceiver.
- Do not operate the transceiver with a damaged antenna. If a damaged antenna comes in contact with the skin, a minor burn may result.
- Do not operate the equipment near electrical blasting caps or in an explosive atmosphere.
- Antennas are excellent conductors of electricity, so use extreme caution when operating near power lines and other sources of electrical current or during stormy weather. If an antenna is installed in a location exposed to lightning, Trimble recommends inserting a lightning surge protector in between the antenna and the radio.

**WARNING** – The radio and its cabling should be installed in accordance with all national and local electrical codes, regulations, and practices. The radio and cabling should be installed where they will not become energized as a result of falling nearby power lines, nor be mounted where they are subjected to over-voltage transients, particularly lightning. Such installations require additional protective means that are detailed in national and local electrical codes.

To reduce potential radio interference to other users, the antenna type and its gain should be an approved Trimble antenna, so that the equivalent isotropically radiated power (e.i.r.p.) is not more than that permitted for successful communication.

## Exposure to hot surfaces

The TDL450B enclosure and heat sink may become very hot during operation, depending on the air temperature, transmit power, and transmission duty cycle. Turn off the unit and let it cool before handling. Always use the heat resistant handle to hold or move the TDL450B radio.

**WARNING** – Touching the heat sink with your skin may result in light burns when the TDL450B radio is working in high air temperature or low ventilation with transmission power and duty cycle at set high levels.

## Rechargeable batteries

The TDL450B radio requires a 9 V to 30 V power source to function. To operate the radio at a higher than 5 W transmission power, you need an input voltage higher than 11 V. Trimble recommends using 12 V deep discharge or 12 V LiFe Po batteries. The battery capacity you need depends on the transmission power setting and duty cycle you are using. A 35 Ah battery should last you at least eight hours of operation. Please refer to the battery manufacturer for usage, charging, and storage recommendations.

**CAUTION** – Storing batteries for an extended period of time in a discharged status will damage them. Please refer to the documentation included with your battery.

**NOTE** – Trimble offers fused battery cables for your convenience. For specific safety information, please refer to the documentation included with your battery.

## Power

The TDL450B radio must be powered by a fused power source capable of delivering 200 W with voltage between 11 V and 30 V. Always use Trimble P/N 130919 power cable to power the radio.

## Wet locations

**WARNING** – The external power adapter and its associated power cord and plug are not intended to be installed outdoors, or in a wet location.

IP Rating: IP67.

# Transmission rules and regulations

## Licensing requirements

It is the responsibility of the owner to comply with the applicable rules and regulations concerning the operation of a radio transmitter. In the United States, the FCC regulates the licensing of this equipment.

The TDL450B transceiver use extended frequencies and may contain functions that are not operational in the United States and its territories. Users should check with the radio authority of the country of operation for any restrictions that may apply.

Application for a license is made by submitting FCC Form 600 along with evidence of frequency coordination (if required) and applicable fees. Similar licensing requirements exist worldwide. Penalties for broadcasting without a license can be severe, and may include confiscation of your radio.

For more information, please contact your dealer or our customer service department.

**CAUTION** – Always obey local licensing requirements and restrictions. It is illegal to transmit in the United States while CSMA is turned off.

## Being part of the RF community

Operation of a licensed radio product makes you a member of the RF community. Be aware that virtually all frequencies licensed are provided on a shared basis with other users. Each frequency dedicated specifically to RTK surveying activities has certain restrictions and limitations. For complete information, refer to the appropriate documentation from the licensing agency in your country of operation.

Most frequencies sharing data transmissions and voice transmissions give priority to voice users. Be mindful of the persistent nature of a GPS RTK data transmission and always limit your RF transmission output power when performing close-in survey situations to avoid interference with co-channel users. Trimble recommends using the low RF power setting for construction sites and other line of sight surveys with baselines less than three kilometers (two miles) depending on terrain. Also consider shutting down your radio transmission when not needed.

The TDL450B radio has embedded tools to help you identify the frequencies that are less used where and when you set up your transmitter.

**CAUTION** – If you are in conflict with a co-channel user, select another frequency to avoid formal actions by government agencies. In most cases, you are required to vacate a frequency upon complaint by a shared channel voice user.

Most survey operations are itinerant in that the system is moved on a frequent basis. For fixed system installations, you should not use frequencies set aside for itinerant operation, but should coordinate a frequency based on the fixed area operation.

Regulations differ from country to country, please be aware of the local regulations before using this radio equipment.

## Automatic station identification

For operation in the United States, the FCC requires that the radio transmitters broadcast a station identifier every 15 minutes. The station identifier is the call sign assigned to you on the station license.

The Trimble TDL450B radio supports the broadcast of station identification in a manner that meets the requirements of the FCC. Upon receipt of equipment, use the radio keypad and display to program your FCC call sign into the configuration of the radio. This is only required for transmitters.

The call sign is transmitted every 15 minutes in Morse code. It is not included in any data packet and so is not processed by the receiving radio. However, data transmission is interrupted for up to four seconds, depending on the number of digits of your call sign, while the call sign is being transmitted. If you leave the call sign field blank, the radio programmed with this configuration will not transmit any call sign.

**WARNING** – Failure to transmit your station identification is in violation of FCC regulations. If you are operating outside the United States, check with the local authorities if you need to transmit a call sign.

## Carrier Sense Multiple Access (CSMA)

CSMA is a technology implemented in the TDL450B radio to meet the FCC transmitter requirements. It is illegal to transmit on any UHF radio within the USA without CSMA enabled. CSMA prevents radio transmission if the frequency is currently being used by a co-channel user. On occasion, you may note that the radio broadcasts stop for short periods of time. This is often due to co-channel interference and the radio is preventing broadcasts due to the FCC-mandated CSMA. The display will tell you that the radio has prevented its transmission because it has detected that the frequency is already being used.

GPS RTK equipment is designed to function with intermittent gaps in the data. Heavy co-channel use may limit the ability of the radio to transmit the required information. In areas of heavy co-channel usage, try changing channels to a less used frequency.

# Contents

Legal Notices .....	2
Safety and Regulatory Information .....	4
Use and care .....	4
Regulations and safety .....	4
FCC compliance statement .....	6
Type approval .....	6
Exposure to radio frequency radiation .....	7
Installing antennas .....	8
Exposure to hot surfaces .....	9
Rechargeable batteries .....	9
Power .....	9
Wet locations .....	9
Transmission rules and regulations .....	10
Contents .....	12
Introduction .....	14
Note about this guide .....	14
Technical support .....	14
Features .....	15
Installation .....	16
Set up in the field .....	17
Set up in the office .....	19
Configuring the Radio Using the Keypad and Display .....	20
LEDs .....	21
Keypad .....	22
Display .....	22
Base/Rover or Repeater mode selection .....	23
Setting the transmit and receive frequencies .....	23
Wireless mode .....	24
Selecting the transmission power .....	24
Setting the radio to receive any frequency .....	24
Advanced features .....	25
Device settings .....	27
Recommended Setup and Configuration .....	31
Available formats .....	31
Radio protocol (wireless mode) setting recommendations .....	32
Rover performance .....	32
Bandwidth enhancement (bandwidth limitation) .....	33

Preferred channels (frequencies) ..... 33

Repeater ..... 33

Other radio performance considerations .....33

Menus ..... 36

Specifications .....39

    Regulations .....39

    Specifications ..... 39

    Physical dimensions ..... 42

    Connector pinouts ..... 43

# Introduction

- [Note about this guide](#)
- [Technical support](#)
- [Features](#)

This manual describes how to set up and use the Trimble® TDL450B radio.

The radio is an advanced, high-speed, wireless data link that is designed specifically for GNSS/RTK applications. Ease-of-use, integration with different Trimble GNSS systems, and field reliability are our primary goals for your success in using this radio.

The radio has a user interface designed to offer full control over the radio field setup, and contains useful tools to troubleshoot and optimize your setup.

This guide is written for the first-time user and provides details on system setup, operation, and maintenance. We strongly recommend that you take time to review this manual before you set up your system.



## Note about this guide

We believe that the TDL450B system provides the best value and performance for users. As such, we offer complete turnkey systems that include all necessary items to operate with your GNSS systems.

You may have purchased this radio from a third-party supplier. Occasionally, the bundled product provided by these sources may differ from the kits provided directly by Trimble. If this guide does not accurately reflect the equipment you received, please contact your supplier for specific instructions on setting up those items that are different.

## Technical support

If you have a problem and cannot find the information you need in the product documentation, contact your local dealer or go to the Support area of [trimble.com](https://www.trimble.com). Product updates, documentation, and any support issues are available for download.

# Features

## Compatibility

- Facilitates radio equipment mix and match.
- Interoperable with Trimble radio products including all Trimble GNSS receivers with 450 MHz embedded radios, Pacific Crest, and SATEL.
- Supports 12.5 kHz and 25k Hz channel bandwidth communications.
- One single radio covers the 403 MHz to 473 MHz band.
- Provides upgrade path for existing installations.

## Enhanced two-level user interface

- Switch between Expert and Simplified user interface.
- OLED long-life high-contrast display with intuitive keypad that is easy-to-read in outdoor sunlit environments.
- View and change radio channel, modulation, protocol types, and much more.
- Monitor device performance: each event logs an alarm to review for troubleshooting.
- Ten radio configurations can be stored and recalled.

## User selectable RF output

- You can select your transmission power to 1 W, 5 W, 10 W, 25 W, and 35 W (maximum, depending on your license).
- Increase range by switching to a higher output power.
- Increase battery life by reducing output power when you do not need the range.

## Designed for harsh environments

- Rugged construction: designed for field work.
- IP67 water and dust ingress protection level to stand up to real-life weather conditions.
- Shockproof and designed to protect the connectors.
- Oversized heat sink to work at high temperatures, with a fan tray accessory (P/N 129681-20) available to push the limits even further.

# Installation

- Set up in the field
- Set up in the office

# Set up in the field

You need the following equipment:

- A TDL450B radio.
- A power cable (TDL450B power cable P/N 130919).
- An 11 V to 30 V power source with an SAE connector protected by a 20 A fuse.
- The GNSS receiver will be powered by the TDL450B radio when connected with one of the data cables: P/N 130918 or P/N 130916. The voltage is typically 12.8 V and the maximum current is 4 A.
- A tripod or any other appropriate antenna support.
- An antenna adapted to the frequency on which you wish to operate with the appropriate cable terminated by a TNC connector. Trimble offers a range of antennas, antenna masts, and accessories; please contact your Trimble dealer.

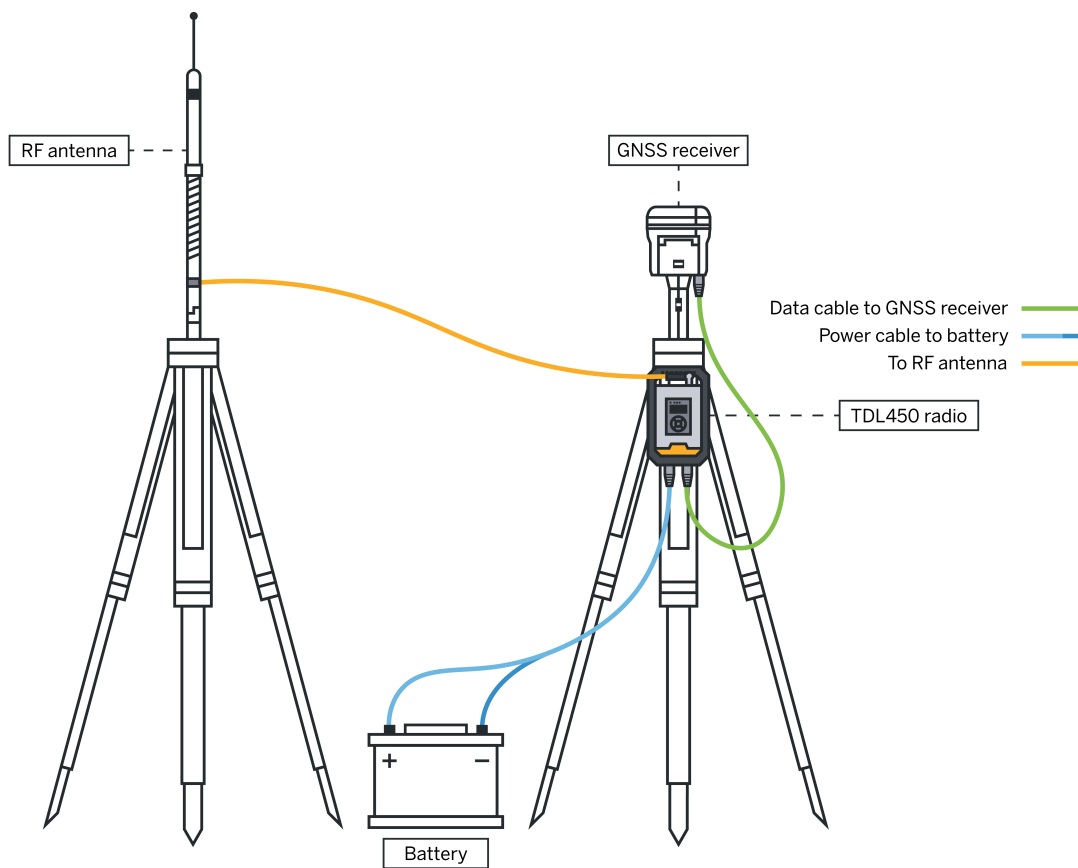

1. Secure the antenna to its support. See [Installing antennas, page 8](#).

**WARNING** – Remember that antennas are excellent conductors of electricity, so use extreme caution when operating near power lines and other sources of electrical current or during stormy weather. Secure the antenna properly in outdoor environments to account for people passing by, wind, or moving vehicles.

2. Secure the radio on the tripod with the hook (P/N 129681-80). This part can be purchased separately.
3. In hot ambient temperatures, Trimble recommends using the fan tray (P/N 129681-20) to help dissipate the heat from the radio heat sink.

#### NOTES –

- The TDL450B fan tray (P/N 129681-20) is equipped with two fans. Their purpose is to extend the temperature in which the radio can work at full power and high-duty cycle. Using the fans is optional. If you want to use them, connect the 5-pin connector on the wall mount cable to the radio data port and connect the data cable from the GNSS receiver to the wall mount connector. This activates the fans as soon as the radio is powered on. The wall mount is IPx4 and although it will withstand water projection from all sides, it will not survive immersion nor physical intrusion in the fans. Please install appropriately.
- Trimble recommends grounding the radio using the grounding tapered hole on the heat sink.

4. Secure the antenna cable to the radio.

**NOTE** – TNC connectors are the ideal option to secure coaxial RF cables on the field. The TNC connectors are nevertheless designed for permanent connections and degrade quickly if repeatedly misused. Trimble recommends using a TNC-to-TNC adapter if the antenna or cable are planned to be repeatedly connected/disconnected.

5. Connect the power cable to the battery SAE connector and to the radio 2-pin power connector. If the **Auto Power On** option is enabled, this starts the radio. For longer use time, you may couple two batteries together using the SAE splitter cord (P/N 89073-00-GEO). Trimble does not recommend coupling more than two batteries in this way. Always check that your power cable or power source has a 20 A fuse.

**NOTE** – Always connect TDL450B radio to your input power source when all other cables are connected. The radio shows the input voltage on the display when it is turned on. If the input voltage falls below 11.5 V during operation, please check the battery, the cables, and the connectors. Dirt, corrosion, or wear has a significant effect on voltage loss in cables.

6. If you do not plan to use the Bluetooth connectivity, connect the selected data cable to the radio and the GNSS receiver.
7. Ensure all cables including from the antenna to the radio are protected from any potential damage or accidental disconnection.
8. Power the radio using the on/off button if the **Auto Power On** option is disabled.
9. The display shows you the radio status and settings. If you want to use the radio interface to configure the radio, see [Configuring the Radio Using the Keypad and Display, page 20](#).
10. Once you have finished using the radio, ensure that you turn it off before you unplug it.

# Set up in the office

You need the following equipment:

- A TDL450B radio.
- A power cable (TDL450B power cable P/N 130919).
- An 11 V to 30 V power source with an SAE connector protected by a 20 Amp fuse.
- Optionally, a data cable if not using Bluetooth technology (TDL450B USB Type A data cable P/N 130927)

1. Connect the SAE connector of the TDL450B power cable to the Office power kit SAE connector and to the radio with the 2-pin LEMO connector.
2. If you are not connecting using Bluetooth, plug the LEMO connector of the data cable to the serial data port on the radio. Connect the USB Type A data cable to your computer.

**NOTE** – On rare occasions, the radio may not be recognized by the computer, especially when using a USB hub. Please plug cable P/N 130927 directly into the computer or use an alternative USB hub if you encounter connection problems.

3. Plug the office power kit into the wall. Always check that all cables are connected before connecting power to the radio.

**CAUTION** – If you are powering the radio with a battery, disconnect any battery charger from the battery.

4. If you are using the Bluetooth connection, pair the computer with the radio.
5. You can now use the radio with the Trimble Access software, Siteworks software, or Trimble Installation Manager.

# 3

## Configuring the Radio Using the Keypad and Display

- LEDs
- Keypad
- Display
- Base/Rover or Repeater mode selection
- Advanced features
- Device settings



## LEDs

There are four LEDs. The LEDs light up as follows:

LED	Color	Indication
PWR	Continuous Red	Correct voltage applied to radio, radio off
	Continuous Green	Correct voltage applied to radio, radio on
	Blinking Red	Unacknowledged alarm
	Blinking Blue	Waiting for a Bluetooth device to connect
	Blinking Red	Connectable but not in pairing mode
	Continuous Blue	Bluetooth connected
Tx	Continuous Red	Transmitting
	Continuous Green	Transmit test active
Rx		Receiving when lit

**CAUTION** – If the Power LED is blinking RED, an alarm has been raised in the radio. This requires your attention to understand and correct the problem. Trimble recommends attending to alarms before continuing use of the radio. The display also shows  on the top row.

On the main display, you can press the **Back** button to access the Alarm list. You can also use the **Device Settings / Alarm list** to access the menu. Once in the **Alarm list** menu, you can acknowledge the alarm by selecting it and pressing **OK**. You can then acknowledge the alarm only, clear the alarm, or clear all alarms. Acknowledging the alarm stops the power LED from blinking red, but also keeps the alarm in the memory for future troubleshooting.

# Keypad



Navigate through the display menus by pressing ▲ and ▼.

Press **OK** to enter the line you are on.

Press ↶ to return one level above the current level.

On the display, the first character on each line (▶ or >) will show you if the item is for information only or a setting you can change by pressing **OK**.

# Display

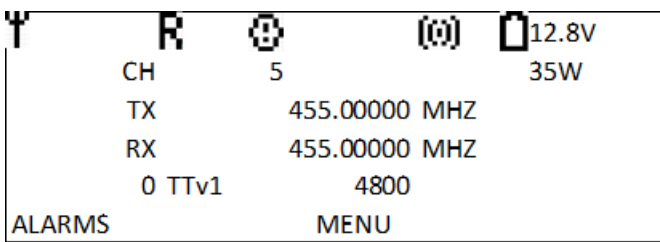

The top row displays (depending on the radio status) a series of icons as well as the input voltage.

 Unacknowledged alarms in the alarm list

 Repeater mode

 Receive only mode

 Remote control mode

Pressing **OK** performs the action indicated in the bottom middle of the display.

Pressing the back button executes the action indicated at the bottom left of the display or go back to the upper menu level.

#### TIPS -

- The display has a back-light timeout to improve lifetime. When the display is black, pressing any button except the **ON** button switches the back-light back on. It has no other effect.
- Press and hold the scroll buttons to continuously scroll down or up.

Navigating through the display menus is done using the up and down buttons. **OK** enters the line you are on and back returns one level above the current level.

On the display, the first character on each line (▶ or ⏴) will tell you if the item is for information only or a setting you can change by pressing **OK**.

The radio interface can be set to Simplified or Expert modes. The Simplified mode gives you access to the most used information and settings, handily decluttering the menus with items you may rarely use. To switch modes, select **Device Settings / UI level**.

For more information, see [Menus, page 36](#).

To configure the radio, use the display and keypad to adjust the radio settings according to your needs.

**CAUTION** – Remember to follow all regulatory limitations. Your UHF transmission license specifies which settings you are allowed to use. If you cannot find a certain setting option mentioned in this manual on your radio, it could be due to restrictions imposed by the regulations in your country of operation.

## Base/Rover or Repeater mode selection

You need to tell the radio how you intend to use it in your network:

- Rover or Base
- Repeater
- Base with One Repeater
- Rx Only

Select **Wireless Settings/Radio mode** menu.

## Setting the transmit and receive frequencies

Your radio comes with your license frequencies already set in your Tx and Rx frequency tables. You can view these using the **Wireless setting / Frequency table Rx** (or **Tx**) menu. To set the frequency you want to transmit or receive on, use the **Current Channel** menu to display and change the current channel.

**TIP** – If you cannot select any channel except for '0', check your Tx and Rx table frequencies. If these are empty, request assistance from your dealer as your license frequencies should be in these tables.

## Wireless mode

There are many protocols offered to suit situations where you do not control the base radio settings. You can select the wireless mode in the **Wireless mode** menu. The radio displays a list of the available wireless modes. Scroll down to your selection and press **OK**. You can press and hold the scroll buttons to continuously scroll down or up.

Trimble recommends to always use **TTv1** at the lowest possible baud rate, depending on the size of the data you need to send. This optimizes range and data integrity.

An over-the-air protocol can be defined by a data format, a modulation, a baud rate, whitening or scrambling, and error correction.

You can select variants by changing each of these settings individually when available if required. See [Menus, page 36](#).

The **Legacy Protocol Name** menu item shows you the description of the selected wireless mode.

For a more complete understanding of the effect of selecting protocols and their variants, see [Recommended Setup and Configuration, page 31](#).

Once you have set your radio, you can save these settings in a profile (go to the **Settings Profiles** menu). The first setting cannot be modified; it is the default setting for your radio that has been recorded by your dealer.

## Selecting the transmission power

Your maximum power transmission depends on your license and country regulations. You can set the transmit power to 1, 5, 10, 25, or 35 W. The higher the power, the bigger the range but the bigger the power consumption. Set the power to the minimum needed to achieve the range you need.

**NOTE** – This manual contains advice on how to set your power and other parameters to optimize your range, throughput and overall reliability of your radio link.

Your TD450B radio should now be ready to operate. You can save these settings in a profile for future use by using the **Setting Profiles** menu.

## Setting the radio to receive any frequency

You may require the radio to be set to a different frequency than the one for which you have a license to transmit. To do this, you can set the radio to Rx Only mode (**Wireless settings / Radio mode / Rx Only**) and select the Rx frequency in the **Wireless settings / Rx Frequency** menu. You can also select the channel spacing freely in the **Wireless settings / Channel bw** menu.

To enable transmission when in receive only, select one of the options in the **Radio mode** menu. This resets your receive frequency and channel spacing.

# Advanced features

## Antenna matching

In Expert UI mode, once your radio is set up as you intend to use it, including the antenna physical setup, you can check if the antenna, the antenna cable, and the position in which you have installed the antenna are optimal:

1. Select the **Radio Status** menu, and then **ANT. TEST** by pressing **OK**. Choose if you want to run a short (about 20 seconds) or long (about 5 minutes) antenna setup test. The long test is more accurate than the short test.
2. Once the test has completed, the radio displays the **Received Signal Strength Indicator (RSSI)** value and rates it as **Bad**, **Acceptable**, or **High**. Trimble does not recommend using the radio when the result is **Bad**.

To improve the result:

1. Check you have installed the correct antenna adapted to the frequency you are transmitting on.
2. Check the cable and connectors. Dirt, corrosion, and humidity reduce the RSSI value.
3. Try moving the antenna with regards to obstructions. Often moving as far away as possible from pylons, buildings, cables overhead or beneath the antenna, or large metallic objects improves the RSSI value.

**NOTE** - The more channels you have in your radio, the longer the test takes. If you have no channels set up (which is not normal), the test will not work.

After the antenna test, the radio displays the **Antenna Quality** value.

## Auto Rover 1

The Auto Rover 1 feature enables you to scan the channels set in your radio to identify any channels that have a corrections broadcast currently available. The radio must be set to the same settings as the broadcasting base radio. Once the broadcast channel is identified, the TDL450B radio configures itself to this channel and begins receiving corrections. The time that Auto Rover listens to the channel can be configured in the **AR Listen time** menu.

## Auto Rover 2

This feature is identical to Auto Rover 1, but when enabled, a scan is automatically performed after it fails to receive corrections from the current base radio for  $n$  seconds. This delay can be configured from 5 to 60 seconds.

## AR Listen time

The Auto rover (AR) Listen Time feature enables you to set the time the Auto Rover functions listen to each channel to analyze whether or not data is being broadcast on that channel. Set the time from 1 to 30 seconds.

## Auto TX

The Auto TX feature scans the transmit channels in the radio to determine which channel is the least noisy. After the scan, it lists the current channel followed by a list of the least noisy channels. Select the transmit channel you want to use.

## CSMA

The TDL450B radio incorporates Carrier Sense Multiple Access (CSMA) technology to comply with FCC transmitter requirements. CSMA prevents the radio from transmitting if the frequency is currently being used by another user. Occasionally, you may notice that the radio broadcasts pause. Usually, this occurs as a result of co-channel interference, and the radio pauses broadcasts to comply with the FCC-mandated CSMA. The display shows that the radio has paused its transmission. This raises an alarm: "CSMA: 1 Pkts L", which means that due to CSMA, the radio did not transmit one data packet.

Trimble recommends using the **Auto TX** feature to identify an available channel in your environment.

**CAUTION** – This menu option enables you to disable CSMA. It is illegal to do so if your license requires CSMA.

## Bluetooth

When enabled, the TDL450B radio features a Bluetooth server and client mode. You can either connect to any visible Bluetooth device or be visible so that another Bluetooth device can connect to the radio.

To open the **Bluetooth** menu, press **▼** until the Bluetooth menu is highlighted, and then press **OK**. The display shows one of the following screens:

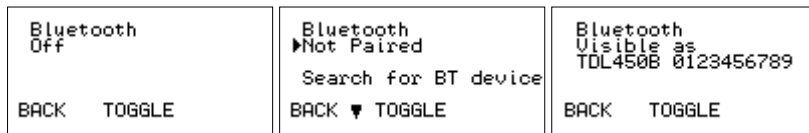

Press **OK** to move between the screens.

When the display shows that the radio is visible as TDL450B xxxxxxxxxx (serial number), you can pair to the radio through the other Bluetooth device by connecting to TDL450B serial number. If you exit the **Bluetooth** menu, the radio is no longer visible to other Bluetooth devices.

When displaying the message Connected to or Not Paired, you can select the **Search for BT device** option to get a list of all visible Bluetooth devices you can connect to. Select the device in the list to initiate the Bluetooth connection.

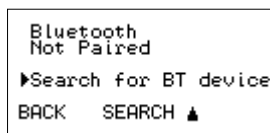

### LOOKING FOR DEVICES...

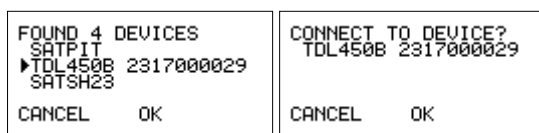

CONNECTED TO *Device Name*

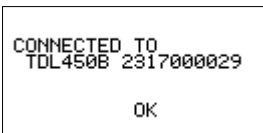

## Device settings

### UI Level

You can select either Expert level with all options displayed or a simplified set of menu options in Simplified mode. See [Menus, page 36](#).

### Serial port settings

Enables you to configure the radio's serial port communication to the GNSS receiver. Please refer to the GNSS receiver settings and set the TDL450B radio identically.

### Owner name

This menu enables you to name the radio. The default name is the serial number. You can edit this name using the keypad.

### Serial Number

This is the unique serial number of the radio.

### Firmware version

The firmware version of the radio. When Trimble releases new firmware for the radio, you can check if the radio is up to date.

### HW version information

These are the different hardware component versions. This can be useful for servicing and troubleshooting.

### Bluetooth name

The Bluetooth name of the radio used by other Bluetooth devices to identify it.

## Power management

The radio does not transmit with 9 V to 11 V power input as this creates excessive current drain. All other functions still work. At 90% duty cycle, The radio uses the approximate amount of power as per the following table:

Transmission power	1 W	5 W	10 W	25 W	35 W
Absorbed power	30 W	50 W	80 W	100 W	115 W

The radio has protection circuits that automatically modify the transmission power as the input voltage drops below or goes above certain levels.

- The radio switches to **Energy saving mode 1** when the input voltage falls below the value specified in **Minimum input voltage before energy saving mode 1**. In this mode, the transmission power is limited to 5 W.
- The radio switches to **Energy saving mode 2** when the input voltage falls below the value specified in **Minimum input voltage before energy saving mode 2**. In this mode, the transmission stops but the radio stays on, enabling you to view the radio status and why it is no longer transmitting.

You can set the two energy saving mode voltages in the **Device Settings** menu to suit your needs.

The radio is also protected against an input voltage above 30 V or a reversed polarity voltage input. You can set the max voltage alarm to suit your needs.

The following menu options are available to configure and monitor TDL450B power management:

### Auto Power On

The options are Disabled or Enabled.

This feature enables you to automatically power the radio when the input voltage is above 9 V. If this option is disabled, press the Power button to power the radio.

### Voltage

Shows the input voltage.

### Operating mode

Informs you if your input voltage is too high or too low for a normal operation. This is useful for troubleshooting.

### Min voltage 1

Enables you to set the voltage at which the radio switches to Energy saving mode 1.

### Min voltage 2

Enables you to set the voltage at which the radio switches to Energy saving mode 2.

## Max voltage

Enables you to set the voltage at which the radio notifies you that the input voltage is too high. You can set this from 8 V to 35 V.

## Display settings

You can set the display back-light intensity (Medium, High) as well as the back-light timeout (10 s, 30 s (default), 1 min, 2 min, 5 min). The OLED display is a long-life display but it is recommended to not unnecessarily extend the timeout.

## Alarms

Each time the radio displays an alarm, it is kept in the alarm list for troubleshooting purposes. You can review the alarms and acknowledge them. If the reason why the alarm was set is no longer present, you can delete the alarm from the list.

- Input voltage: Indicates when the input voltage is higher or lower than the user defined limits. Remedy this alarm by adapting the input power voltage.
- Temperature: Indicates when the radio internal temperature is too high and the radio reduces the transmission power. Remedy this alarm by setting up the radio with the fan tray or in a cooler place. Reducing the Tx power will also help.
- Saturation: Indicates when the signal level the radio receives is too high, creating a saturation effect. Remedy this alarm by reducing the power of the radio transmitting the signal or by moving the Rx radio further away from the Tx radio.
- CSMA: Indicates the frequency the radio is trying to transmit on is already busy. This stops transmission. Remedy this by choosing a different Tx frequency.

## Remote Control

The options are Disabled or Enabled.

In the near future, for a selection of Trimble GNSS receivers, the field applications will be able to control the radio by remote control. In remote control mode, the radio communicates its status to the field application.

If the GNSS receiver is not compatible with this functionality, the radio automatically pauses remote control, but you still have full control of the radio using the keypad and display.

When you connect the TDL450B radio to a Trimble GNSS compatible receiver, the radio automatically switches to remote control mode. You can still use the keypad and display to change settings on the radio; these are updated in the field application one minute after the last action on the keypad.

You can manually switch the remote control to off.

**NOTE** - This is necessary if you use a non-compatible GNSS receiver when using the TDL450B radio as a UHF radio receiver.

## Profiles

You can save up to ten profiles. Profiles remember the following settings:

- Radio operating mode (Base/Rover, Repeater, or Receive only)
- Rx and Tx channels
- Wireless mode
- Tx power
- BT configuration
- UI level setting
- Auto power on setting
- Energy saving voltage levels for mode 1 and 2
- Maximum input voltage before the alarm is set
- Display brightness and timeout

The first profile in the list is permanent and contains the default radio settings that were present when you received the radio.

You can save the current setting in a profile in the **Setting Profiles** menu.

# Recommended Setup and Configuration

- Available formats
- Radio protocol (wireless mode) setting recommendations
- Rover performance
- Bandwidth enhancement (bandwidth limitation)
- Preferred channels (frequencies)
- Repeater
- Other radio performance considerations

Precise positioning using RTK techniques requires that a GNSS rover receiver receives observations (also known as *corrections*) from a GNSS base station (also known as a *base receiver*). Broadcasting these observations for the ever-increasing GNSS constellations and number of satellites has become challenging in recent years. The data formats in which the GNSS base station encodes this data have adapted by becoming more compact, resulting in multiple formats being available.

Precise Point Positioning (PPP) solutions, such as Trimble RTX®, that use proprietary formats and are normally delivered over an MSS band satellite link are not covered in this manual.

## Available formats

Format	All Constellations	Trimble only	Size per SV	Optimized for radio operation	Recommendation
CMR	No	No	Good	No	
CMR+	No	No	Good	Yes	
CMRx	Yes	Yes	Best	Yes	For Trimble base and rover only
ATOM standard (4)	Yes	No	Best	Yes	For Spectra Geospatial base and rover
ATOM Compact (100)	No	No	Best	Yes	GPS, GLONASS, Galileo, Beidou

Format	All Constellations	Trimble only	Size per SV	Optimized for radio operation	Recommendation
ATOM super compact (101)	No	No	Best	Yes	GPS, GLONASS, Galileo, Beidou
RTCM v2	No	No	Poor	No	
RTCM V3 Non-MSM	No	No	Good	No	
RTCM V3 MSM	Yes	No	Good	No	If CMRx or ATOM is not available at Base or Rover

For best performance, select the following formats:

Base / Rover	Trimble	Spectra Geospatial	Other
Trimble	CMRx	CMRx	RTCM V3 MSM
Spectra	CMRx	ATOM	RTCM V3 MSM
Other	RTCM V3 MSM	RTCM V3 MSM	RTCM V3 MSM

## Radio protocol (wireless mode) setting recommendations

Trimble recommends using the TRIMTALK™ v1 protocol for Trimble products. Although the radio protocols have some impact on the bandwidth, a general rule to determine the maximum data size (in bytes) you can send is to divide the baud rate by 10. For example, a baud rate of 19200 enables you to send up to 1920 bytes, while a baud rate of 4800 enables you to send up to 480 bytes.

*Some protocols may not be available in your country due to local regulations.* These protocols are not included in your setup configuration.

When selecting a protocol, you must also consider other factors besides bandwidth. If bandwidth allows, it is recommended to have Forward Error Correction (FEC) enabled. Enabling FEC uses 35% of the bandwidth in PCC FST and SATEL formats, and 50% in PCC EOT and EOT 4 formats.

## Rover performance

The RTK performance of the rover receiver does not depend on the format (except for RTCM v2) of the base station observables in use in any significant way.

The difference in performance is based on:

- how many satellites can be transmitted over the radio link.
- how the base antenna information is transmitted.

Note that the vendor of the base station does make a difference, regardless of the format used:

- There can be interoperability issues of the measurements made between different vendors, as well as interoperability issues based on the application of antenna models.
- When using a Trimble base station with modern firmware, the xFill offset is transmitted to the rover receiver allowing xFill to be available much faster than with a third-part or older base station.

The best performance for Trimble equipment is achieved with a Trimble base station. The best performance for Spectra Geospatial equipment is achieved with either a Spectra Geospatial or Trimble base station.

## Bandwidth enhancement (bandwidth limitation)

**NOTE** - Available in GNSS receiver firmware version 5.50/6.00.

Starting with firmware version 5.5 on Trimble GNSS receivers equipped with an internal radio, the GNSS base station selects the ideal number of satellites for which it sends observations through the radio, depending on the format and protocol you have selected. For a Trimble GNSS base station connected to an external UHF radio, you must enable this option. ***To ensure optimal RTK performance, we strongly recommend always enabling this option.*** The amount of data broadcast every time frame never goes over the setting capability, thus resulting in a small correction age. Firmware version 5.5 or later is only required on the GNSS base station.

## Preferred channels (frequencies)

The TDL450B radio uses an 18 MHz digitally compensated crystal reference oscillator. These emit minimum energy at harmonic frequencies, hence minimizing the effect of harmonic interference on other radio users. However, harmonics of the unit's reference crystal at 18 MHz can internally interfere with received signals at frequencies that are exact multiples of 18 MHz: 414, 432, 450, and 468 MHz. To minimize the risk for harmonic interference, avoid using these frequencies.

## Repeater

Adding a repeater in the setup reduces the available bandwidth. The repeater stores the data received from the base station and then broadcasts it. This occurs in one cycle, thus dividing the bandwidth by two.

## Other radio performance considerations

### Influence of the antenna height on range

There are many options to set up the radio antennas. They can be assembled directly on the GNSS receiver, be placed on a tripod mount, or mounted on top of a 1.82 m (6 ft) fiberglass mast. The antenna gain can also be set to either 1 db or 5 db.

When all other parameters are kept constant:

- increasing the transmitter (Tx) antenna height from 2 m to 3 m increases the range by about 15%. This can be achieved by using the tripod side mount kit with extension pole.
- increasing the Tx antenna height from 2 m to 4 m increases the range by 30%. This can be achieved by using the radio antenna mast – telescopic.

It is important to consider the placement of the antenna in relation to the rover receiver. Avoid all obstacles that block or deflect the radio signals, such as buildings and power lines.

## Influence of the baud rate on range

Trimble recommends using the TRIMTALK v1 protocol on 400 MHz band radios. The baud rate setting negatively affects the range, while only marginally increasing the throughput. ***Please note that not all settings are available in all countries to comply with local regulations.***

TRIMTALK v1 @ 4800 bauds have 20% longer range than 9600 bauds and 40% to 50% longer range than 16000 bauds or higher. However, the latter two options only provide 700 bytes/epoch throughput compared with 516 bytes/epoch for 4800 bauds, when Bandwidth enhancement is enabled. Keep in mind, 4800 bauds (bps) also consumes more power and generates more heat for a given data size than 9600 or 16000 bauds (bps).

## Input voltage for external radios

12 V batteries output 13.8 V when in good condition and fully charged. Older or partially discharged batteries output much lower voltages. At these lower voltages, the radio has a shorter range. Long power cables, worn out cables, and corroded connectors all contribute to lowering the input voltage and should be avoided.

## Cable lengths and connectors

Keep the coaxial cables from the radio to the antenna as short as possible. Cable and antenna connectors are a source of signal loss. Keep them clean and change both cables and antennas if there are any visible signs of wear. Any rotation, play, wear, and/or corrosion on the central pin of these connectors is a sign that it needs replacing. This last point also applies to the TNC connector on the radio. This is the reason why the radio is shipped with a TNC-to-TNC adapter. If you frequently connect and disconnect the antenna or antenna cable, Trimble recommends using this adapter to avoid the need to replace the TDL450B TNC antenna connector.

## Influence of radio power on range

Currently, Trimble GNSS receivers are built with an optional 1 or 2 W 400 MHz band UHF internal radio. The TDL450B radio has a 35 W maximum power output although this can be limited by your license.

When all other parameters are kept constant, increasing from 1 W to 24 W approximately doubles the range.

The theoretical range reduction from 35 W to 20 W transmission is about 15%. There are many advantages of using 20 W versus 35 W such as battery life and the ability to work in higher ambient temperatures.

## Higher ambient temperature configurations

The TDL450B radio, like any high-power UHF radio, generates heat. The heat sink at the back of the radio is designed to cool down the radio. In high ambient temperature environments, the capacity of the heat sink to keep the radio electronics at a level that prevents damage or excessive wear becomes a limiting factor in the radio performance.

The radio has internal embedded processes that automatically reduce the transmission power when it reaches these critical temperatures. The reduced transmission power reduces the range at which the broadcast can be received correctly. When this occurs, the radio raises an alarm so that you can take appropriate action for future broadcasts.

The first recommendation when working in high ambient temperature environments is to ensure good ventilation of the heat sink. The Fan tray (P/N 129681-20), by generating forced air flow over the heat sink, greatly helps in keeping the radio under the critical temperatures. However, the amount of heat generated by the radio also highly depends on its configuration. Some configurations cause the radio's transmitter to stay on for longer periods, and the longer the radio is actually transmitting, the more heat it generates. Reducing the size of the data you are transmitting by using a compact format, such as CMRx, or the number of satellite corrections you are broadcasting helps reduce the transmission time. Reducing the transmission power also reduces the heat generated by the radio. Trimble recommends setting the transmission power to the level actually required for the needed range, especially in high ambient temperature environments. You can compensate the loss of range with a higher gain antenna or place the antenna higher above the ground and away from any objects that could block its signal.

# Menus

Navigating through the menus is done using the **Up** and **Down** buttons. Press **OK** to enter the line you are on. Press **Back** to return one level above the current level.

On the display, the first character on each line (▶ or ⌵) tells you if the item is for information only or a setting you can change by pressing **OK**.

The radio can be set to **Simplified** or **Expert** modes. The Simplified mode gives you access to the most used information and settings, handily decluttering the menus with items you may rarely use. To switch modes, select **Device Settings / UI level**.

In the following table, menus in the Simplified mode are shown in **bold**.

First menu level	Second menu level	Notes	Information or Setting	Simplified (S) or Expert (E)	Saved in Profile?
Radio status	RSSI	-130 to -20 dBm depending on reception level. See <a href="#">page 25</a> .	Information	E	-
	<b>Antenna Quality</b>	See <a href="#">page 25</a> .	Information	S/E	-
	Estimated VSWR	not measured!	Information	E	-
	<b>Duty cycle</b> (current)	0 to 100%	Information	S/E	-
	<b>Voltage</b> (input)	5 to 28 V. See <a href="#">page 34</a> .	Information	S/E	-
	<b>Temperature</b>	Internal temperature. See <a href="#">page 39</a> .	Information	S/E	-
	Region Code	EU, USA, Canada, ROW, ROW ETSI, South Korea	Information	E	Yes
	CSMA	See <a href="#">page 26</a> .	Information	E	-
	Max TX power	1, 5, 10, 25, 35 W. See <a href="#">page 24</a> .	Information	E	-
	Call sign ID	Displayed only if region code is USA. See <a href="#">page 11</a> .	Information	E	-
	Channel Spacing	12.5 kHz, 25 kHz. See <a href="#">page 24</a> .	Information	E	Yes

First menu level	Second menu level	Notes	Information or Setting	Simplified (S) or Expert (E)	Saved in Profile?
<b>Wireless settings</b>	<b>Radio mode</b>	Rover/Base, Repeater Base with one, Repeater, Rx Only. See <a href="#">page 23</a> .	Setting	S/E	Yes
	<b>Frequency table Tx</b>	List of preset transmit frequencies for each channel. See <a href="#">page 23</a> .	Information	S/E	-
	<b>Frequency table Rx</b>	List of preset receive frequencies for each channel. See <a href="#">page 23</a> .	Information	S/E	-
	<b>Current Channel</b>	Current channel with transmit and receive frequencies and channel spacing. See <a href="#">page 23</a> .	Information	S/E	Yes
	<b>Wireless Mode</b>	Selected wireless mode in available wireless mode list. See <a href="#">page 24</a> .	Setting	S/E	Yes
	<b>Tx Power</b>	Limited to the Max TX power setting. See <a href="#">page 24</a> .	Setting	S/E	Yes
	Auto Rover 1	See <a href="#">page 25</a> .	Setting	E	-
	Auto Rover 2	See <a href="#">page 25</a> .	Setting	E	-
	AR Listen Time	See <a href="#">page 25</a> .	Setting	E	-
	Auto TX	See <a href="#">page 26</a> .	Setting	E	-
	Legacy protocol name	See <a href="#">page 24</a> .	Information	E	-
	Channel bw (bandwidth)	12.5 kHz, 25 kHz. See <a href="#">page 24</a> .	Setting	E	-
	Modulation	See <a href="#">page 42</a> .	Information	E	-
	Air link speed	4800 bps, 8000 bps, 9600 bps, 16000 bps, 19200 bps.	Setting	E	-
	FEC (Forward Error Correction)	ON, OFF. See <a href="#">page 32</a> .	Setting	E	-
	Error Checking	ON, OFF. See <a href="#">page 24</a> .	Setting	E	-
	Whitening	ON, OFF. See <a href="#">page 24</a> .	Setting	E	-
	CSMA	See <a href="#">page 26</a> .	Setting	E	-
	<b>Bluetooth</b>	See <a href="#">page 26</a> .	Setting	S/E	Yes

First menu level	Second menu level	Notes	Information or Setting	Simplified (S) or Expert (E)	Saved in Profile?
Device Settings	<b>UI level</b>	Simplified, Expert	Setting	S/E	Yes
	<b>Serial port settings</b>	See <a href="#">page 27</a> .	Setting	S/E	-
	Owner name	See <a href="#">page 27</a> .	Information	E	-
	Serial Number	See <a href="#">page 27</a> .	Information	E	-
	Firmware version	See <a href="#">page 27</a> .	Information	E	-
	HW version information	See <a href="#">page 27</a> .	Information	E	-
	Bluetooth name	See <a href="#">page 27</a> .	Information	E	-
	Auto Power On	See <a href="#">page 28</a> .	Setting	E	Yes
	<b>Voltage</b>	Input voltage. See <a href="#">page 28</a> .	Information	S/E	-
	Operating mode	With regard to voltage. See <a href="#">page 28</a> .	Information	E	-
	Min voltage 1	Minimum input voltage before going into energy saving mode 1. See <a href="#">page 28</a> .	Setting	E	Yes
	Min voltage 2	Minimum input voltage before going into energy saving mode 2. See <a href="#">page 28</a> .	Setting	E	Yes
	Max voltage	Maximum voltage before alarm sounds. See <a href="#">page 29</a> .	Setting	E	Yes
	<b>Display brightness</b>	See <a href="#">page 29</a> .	Setting	S/E	Yes
	Display timeout	See <a href="#">page 29</a> .	Setting	E	Yes
	<b>Alarm list</b>	See <a href="#">page 29</a> .	Setting	S/E	-
	Remote Control	See <a href="#">page 29</a> .	Setting	E	-
Setting profiles	<b>Save to profile</b>		Setting	S/E	-
	<b>Load from profile</b>	See <a href="#">page 29</a> .	Setting	S/E	-
	<b>Delete profile</b>		Setting	S/E	-

# Specifications

- [Regulations](#)
- [Specifications](#)
- [Physical dimensions](#)
- [Connector pinouts](#)

Specifications are subject to change without notice.

## Regulations

See [Safety and Regulatory Information](#), page 4.

## Specifications

General	Value	Notes
Operating DC voltage input range	9 to 11 V DC Maximum 5 W output	
	11 to 30 V DC fully functional	
Output DC power	typically 12.8 V	
	Maximum 4 A output	
Temperature range	-20 to +55 °C	Functional (complies with standards)
	-30 to +65 °C	Functional
	-40 to +85 °C	Storage

General	Value	Notes
TX power consumption, $T_a = 20$ to $25$ °C, no GNSS load	typically 7 to 10 W	$RF_{out} = +30.0$ dBm (1 W), 403 to 473 MHz, $V_{in} = 11$ to 30 V DC
	typically 14 to 18 W	$RF_{out} = +37.0$ dBm (5 W), 403 to 473 MHz, $V_{in} = 11$ to 30 V DC
	typically 24 to 32 W	$RF_{out} = +40.0$ dBm (10 W), 403 to 473 MHz, $V_{in} = 11$ to 30 V DC
	typically 55 to 72 W	$RF_{out} = +44.0$ dBm (25 W), 403 to 473 MHz, $V_{in} = 11$ to 30 V DC
	typically 76 to 101 W	$RF_{out} = +45.4$ dBm (35 W), 403 to 473 MHz, $V_{in} = 11$ to 30 V DC
Tx power consumption, $T_a = 20$ °C to $25$ °C, GNSS load = 4 A	typically 63 to 66	$RF_{out} = +30.0$ dBm (1 W), 403 to 473 MHz, $V_{in} = 11$ to 30 V DC
	typically 70 to 75	$RF_{out} = +37.0$ dBm (5 W), 403 to 473 MHz, $V_{in} = 11$ to 30 V DC
	typically 82 to 89	$RF_{out} = +40.0$ dBm (10 W), 403 to 473 MHz, $V_{in} = 11$ to 30 V DC
	typically 113 to 130 W	$RF_{out} = +44.0$ dBm (25 W), 403 to 473 MHz, $V_{in} = 11$ to 30 V DC
	typically 76 to 101 W	$RF_{out} = +45.4$ dBm (35 W), 403 to 473 MHz, $V_{in} = 11$ to 30 V DC
Rx power consumption, $T_a = 20$ to $25$ °C GNSS load = 4 A	typically 2.0 to 2.7 W	403 to 473 MHz, $V_{in} = 11$ to 30 V DC
Power consumption in sleep mode (SL+S=8) $T_a = 20$ to $25$ °C No GNSS load	typically 58 to 59 W	403 to 473 MHz, $V_{in} = 11$ to 30 V DC
Power consumption in sleep mode (SL+S=8) $T_a = 20$ to $25$ °C No GNSS load	typically 0.7 to 1.4 W	403 to 473 MHz, $V_{in} = 11$ to 30 V DC
Inrush current, DC voltage turned ON	<20 A	
Vibration	TBD	
ESD <sup>1</sup>	± TBD kV	Antenna connector Acc. to <i>EN 61000-4-2</i>
	± TBD KV	Data port Acc. to <i>EN 61000-4-2</i>

General	Value	Notes
Weight	1.96 kg	
IP classification	IP67	
Dimensions	231.2 × 151.2 × 77.0 mm	

<sup>1</sup> Measured under normal ambient conditions,  $T_A = 20$  to  $25$  °C. When the device is used in different environment, the results may change significantly. It is recommended to use external ESD protection in demanding conditions.

Radio			
	Receiver	Transmitter	Notes
<i>Test conditions: <math>V_{DC} = +12</math> V, <math>T_a = 20</math> to <math>25</math> °C unless otherwise noted</i>			
Frequency range <sup>1 2</sup>	403 to 473 MHz		
Tuning range	70 MHz		
Channel bandwidth	12.5, 25 kHz		
Channel spacing	12.5, 25 kHz		Programmable
Maximum RF frequency step	6.25 kHz		
Frequency stability	±0.5 ppm		-40 to +85 °C (referenced to +25 °C)
Maximum receiver input power without damage	+10 dBm		
Maximum receiver input power without transmission errors	-10 dBm		
Transmitter power		+30.0 (1W) dBm +37.0 (5 W) dBm +40.0 (10 W) dBm +44.0 (25 W) dBm +45.4 (35 W) dBm	
Communication mode	Half-duplex		
Frequency change time	typically 20 ms		
Immunity test	3 V/m		

<sup>1</sup> Firmware rejects 405.925 to 406.176 MHz frequencies. The frequency band is reserved internationally for emergency transmitters as specified by FCC reference FCC 04-75.

<sup>2</sup> In Canada, this product is certified to use frequencies 406.1 to 430 MHz and 450 to 470 MHz. Using this device in Canada outside these frequencies is prohibited.

**Data modem**

Timing	RS-232
Electrical interface	RS-232
Data speed of RS-232 interface	9600, 19200, 38400, 57600, 115200 bps
Data bits	8N1, 8N2, 8E1, 8E2, 8O1, 8O2
Modulation (on-air bit rate)	
4FSK	19200 bps (25 kHz) 9600 bps (12.5 kHz)
GMSK	19200, 16000, 9600, 4800 bps (25 kHz) 9600, 8000, 4800 bps (12.5 kHz)
Air Interface Encryption	None
Data format	Asynchronous data

## Physical dimensions

All dimensions are in millimeters (mm).

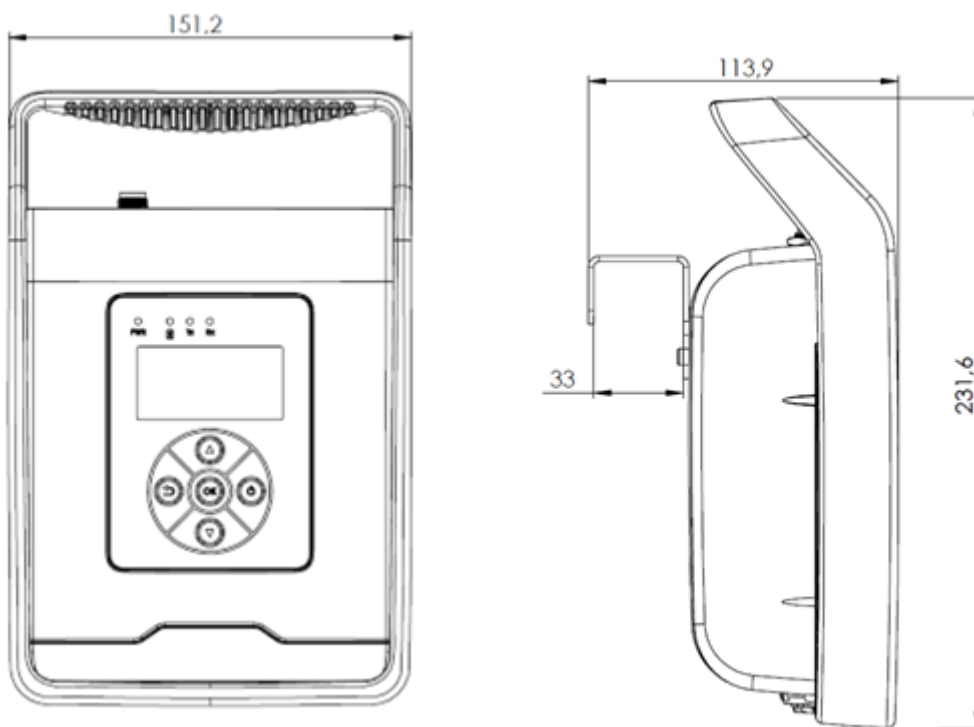

# Connector pinouts

## LEMO connector

The radio uses a #1-shell, 5-pin circular data/power connector. For a mating connector, Trimble recommends using a LEMO connector (FGG.1B.305.CLAD72Z or equivalent). The following table shows the radio's pin assignments:

Pin	Description
1	9 to 30 V DC (operation voltage to the GNSS receiver)
2	Ground for power
3	Rx (connects to the external device's Rx pin)
4	Signal ground
5	Tx (connects to the external device's Tx pin)

The following figure shows the orientation of the pins in the radio's female data/power connector. It shows a front view of the pinouts (looking from outside the radio).

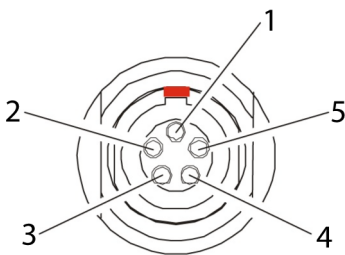

## Power connector

2-pin ODU, G82B0C-P02LTS0-0000

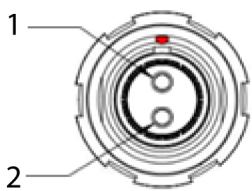

Pin	Name	Description
1	PWR (+)	9 to 30 V DC (operation voltage)
2	GND	Ground

